

# UV LASER ENGRAVER

## SCULPFUN V5 USER MANUAL

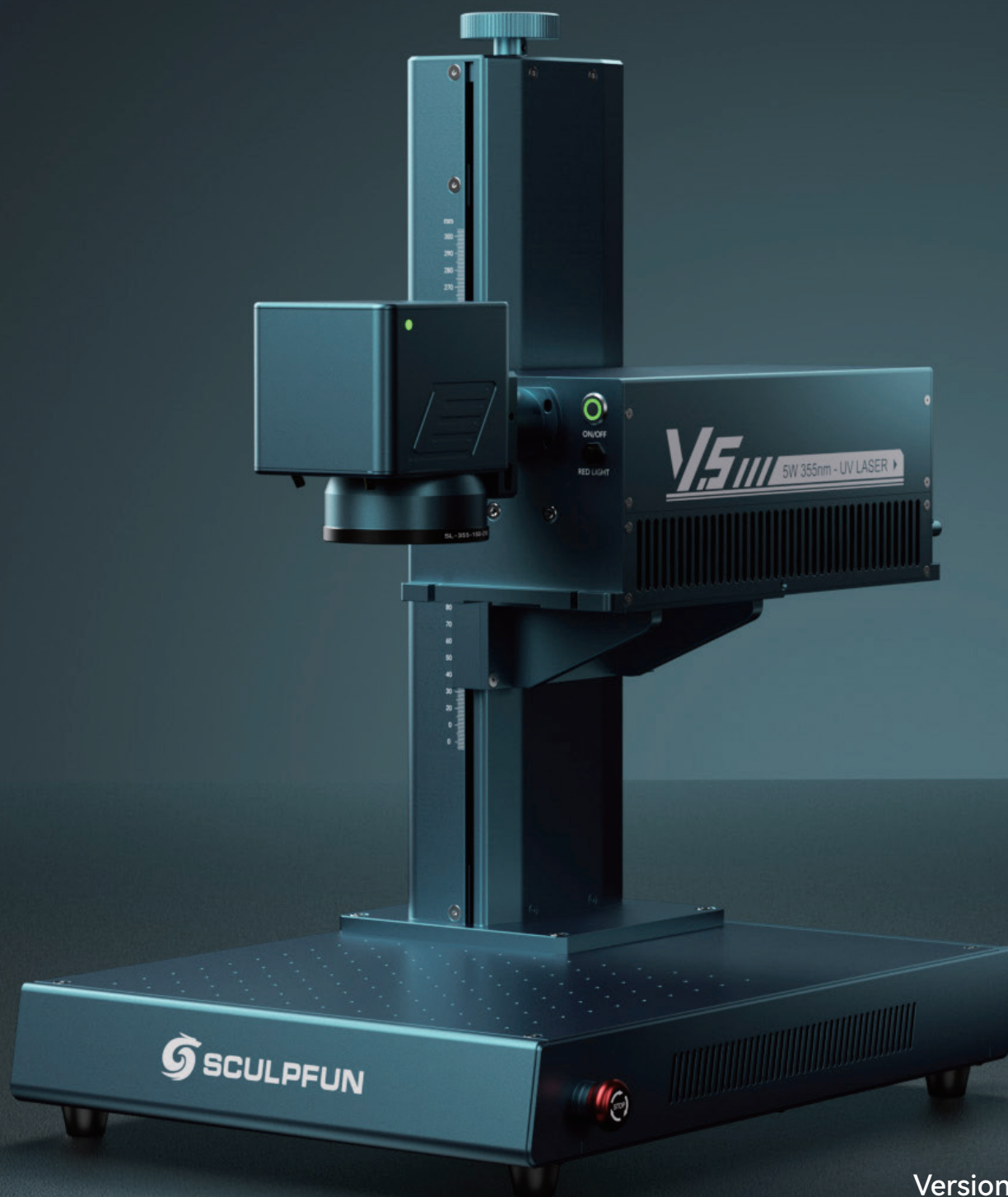



# Contents

|  |    |
|--|----|
| 1. Safety Information                    | 01 |
| 2. Packing List                          | 02 |
| 3. Machine Specifications                | 03 |
| 4. Interface Overview & Machine Labels   | 04 |
| 5. Assembly Instructions                 | 06 |
| 6. Machine Startup & Focusing            | 07 |
| 7. Software Guide (SGD & LightBurn)      | 08 |
| 8. FAQ                                   | 19 |
| 9. Machine Maintenance                   | 19 |
| 10. After-sales Service & Warranty Terms | 20 |
| 11. Disclaimer                           | 20 |



Scan the QR code for more languages, video tutorials, and the [mobile app guide](#)

## 1. Safety Information

**Be sure to read the instructions carefully before operating the machine!**

Before using the laser engraver, please read this safety guide carefully.

- Do not leave the machine unattended while it is operating. Always ensure it is functioning properly.
- Inspect the machine for damage before each use. Do not operate if any damage or defects are found.
- Make sure the work area is clean and level.
- Do not disassemble or modify the machine without authorization. Do not alter or recompile its operating system.
- Keep the inside of the machine clean. Residues and debris generated during cutting or engraving may pose hazards and create fire risks.

Regularly clean the work area to remove chips and debris.

### 1. Laser Safety

This machine uses a Class IV laser, which is extremely powerful and can cause serious eye injury or skin burns. It is strongly recommended to wear laser safety goggles when operating the laser engraver.

Avoid direct skin exposure to the Class IV laser beam, especially at close range. Minors must be supervised by a parent or guardian when using this machine. Do not touch the work area while the laser beam is active.

### 2. Material Safety

Do not engrave materials of unknown composition. Recommended materials include: Metals: Stainless steel, aluminum, bronze, brass, alloys, etc. Plastics: PP, PE, ABS, etc. Non-metals: Wood, leather, cardboard, etc.

### 3. Usage Safety

Never point the laser at people, animals, or any flammable objects, regardless of whether the device is powered on or off. Always operate the laser engraver in compliance with all applicable local and national laws and regulations. Use the device strictly in accordance with this manual and the operating instructions of the engraving software. Ensure that untrained personnel near the device are made aware of potential hazards before operation.

### 4. Electrical Safety

Use only a compatible and stable power supply. Ensure that voltage fluctuations do not exceed 5%. Verify that the device is properly grounded before powering it on. Keep the environment around the laser engraver dry and well-ventilated. Maintain an ambient temperature between 10°C and 28°C, with humidity not exceeding 70%.

#### Note:

This machine performs best in an environment between 10°C and 28°C. Operating outside this temperature range may cause the laser to stop functioning.

## 2. Packing List

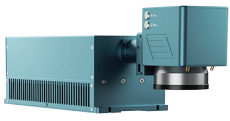

UV Laser\*1



Base Assembly\*1



Lifting Column\*1



70×70 Field Lens\*1



150×150 Field Lens\*1  
(pre-installed)



Screw Kit\*1



Power Cable\*1



Data Cable\*1



Rotary Module  
Adapter Cable\*1



Extension Cable\*1



User Manual\*1



Goggles\*1



Ruler\*1



Focusing Sheet\*5



Basswood  
Board\*2



Calibration  
Paper\*5



Crystal Pillar\*2



U Disk\*1



Positioning Bar\*2



Level \*2  
(shipped  
separately)

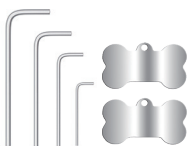

Tool Kit\*1



Security Key\*1

### 3. Machine Specifications

|                               |   |
|-------------------------------|---|
| Product Name                  | UV Laser Engraver   |
| Model                         | V5  |
| Laser Power                   | 5-6W  |
| Laser Wavelength              | 355nm   |
| Spot Size                     | 0.0019mm  |
| Speed                         | 10000mm/s   |
| Supported Material Types      | Metals, plastics, wood, leather, acrylic, stone, ceramics, glass, paper<br>(capable of engraving almost all types of materials) |
| Working Area                  | 150*150mm & 70*70mm   |
| Repeated Positioning Accuracy | 0.001mm   |
| Focusing Operation            | Electric Lifting  |
| Supported Operating Systems   | Android/iOS/Windows/MacOS   |
| Application                   | SGD Laser/lightburn (Purchased Separately)  |
| Supported File Formats        | SVG/DXF/JPG/JPEG/PNG/BMP  |
| Connection Method             | WIFI/USB  |
| Operating Voltage             | 110V/230V   |
| Operating Current             | 6.5A/3.17A  |
| Machine Dimensions            | 387*592*638mm   |
| Machine Weight                | 26.7 kg   |
| Packing Dimensions            | 700*480*420mm   |
| Package Weight                | Approx. 33 kg   |

# 4. Interface Overview & Machine Labels

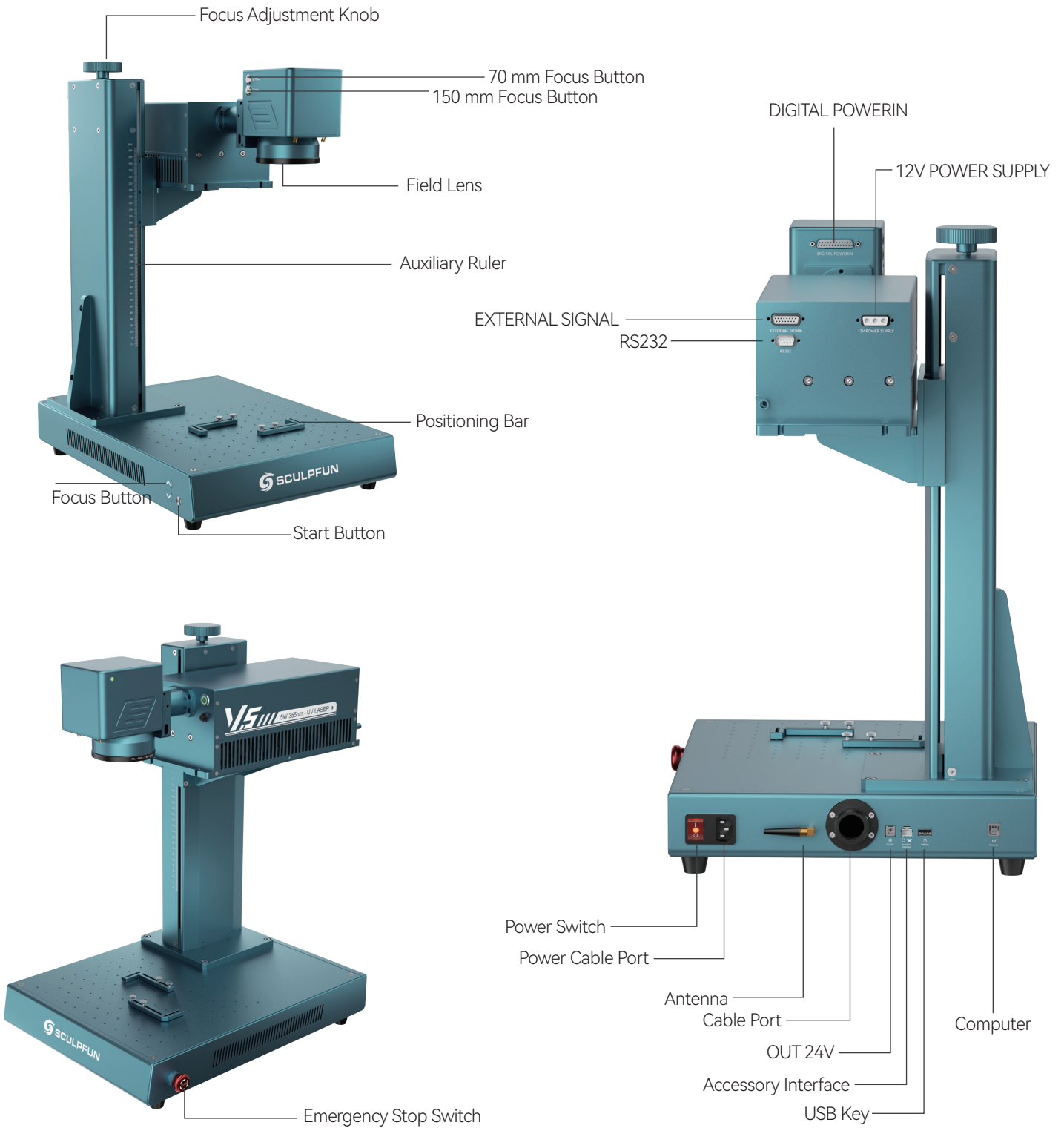

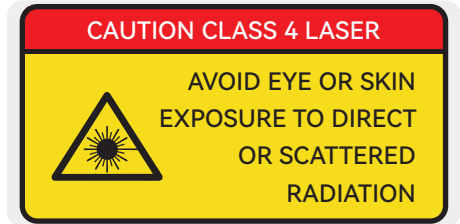
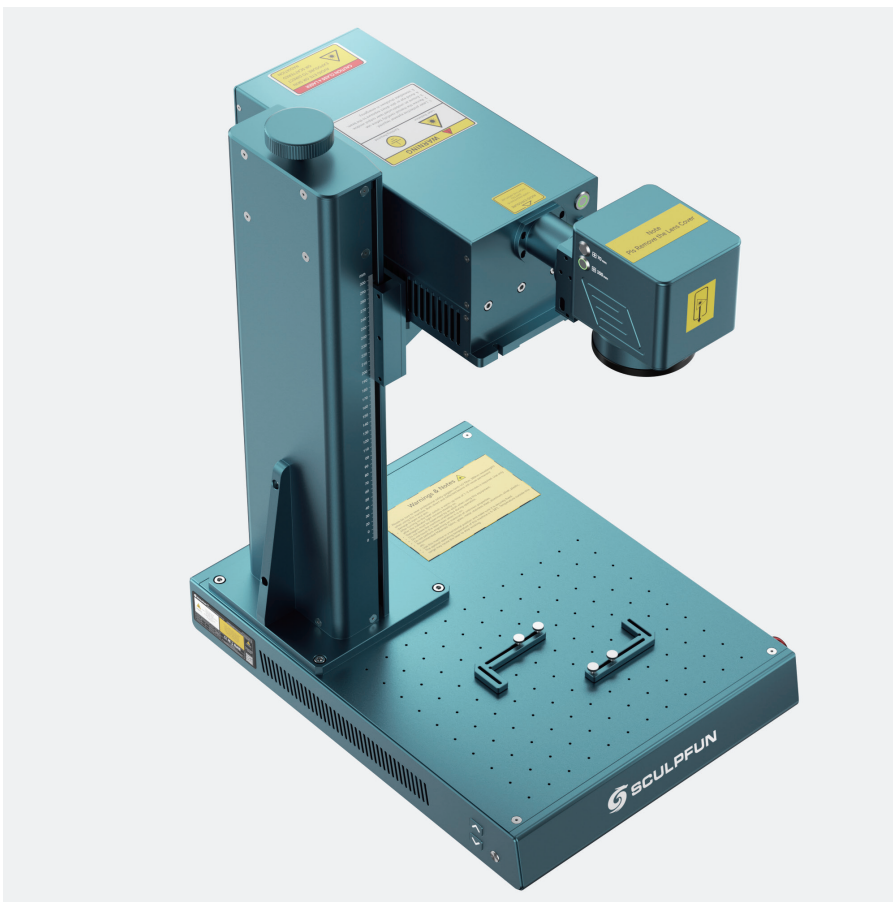

**SCULPFUN V5** SHENZHEN SCULPFUN TECHNOLOGY CO., LTD. MADE IN CHINA YEAR OF MANUFACTURE: 2025  
 THIS PRODUCT COMPLIES WITH 21 CFR 1040.10 AND 1040.11 EXCEPT FOR DEVIATIONS PURSUANT TO LASER NOTICE NO. 56, DATED FEBRUARY 21, 2023

**⚠ DANGER LASER 4**  
 AVOID EYE OR SKIN EXPOSURE TO DIRECT OR SCATTERED RADIATION

Maximum Output: 5W-6W IEC 60825-1:2014  
 Wavelength: 355nm EN 60825-1:2014+A11:2021  
 CLASS 4 LASER PRODUCT EN 50689:2021

**CAUTION -AVOID EYE OR SKIN EXPOSURE TO DIRECT OR SCATTERED RADIATION LASER ENERGY -EXPOSURE NEAR APERTURE MAY CAUSE BURNS**

**CAUTION**  
 Avoid running the machine without supervision

|               |                            |                |                            |
|---------------|----------------------------|----------------|----------------------------|
| Product Name  | UV Laser Engraving Machine | Input Power    | 110V / 230V / 3.17A / 4.5A |
| Product Model | V5                         | Engraving Size | 70*10mm / 60*10mm          |
| Machine Size  | 387*92*138mm               | Machine Weight | 2.67KG                     |

**CE FC RoHS**

Room 401, Building 13, No. 140, Guanlan Avenue, Site Community, Fucheng Street, Longhua District, Shenzhen City, China

sculpfun.com  
 E-mail: support@sculpfun.com

**⚠ WARNING**

**⚠ Laser Radiation**      **⚡ Earthing Required**

1. Laser protective eyewear required.
2. Review the manual carefully before use.
3. Ensure an unobstructed laser output window.
4. Avoid eye or skin direct exposure to the beam.
5. Immediate shutdown in emergency.

**Warnings & Notes** ⚠

- Please be sure to wear professional safety goggles (anti-UV filter, 380nm wavelength) when using this machine. Both direct and reflected beams will cause permanent damage to eyes and skin.
- After turning on the laser switch, a warm-up time of 1-2 minutes is required. Use only after the indicator light remains steadily on.
- Teenagers must be supervised by an adult when using this equipment.
- Do not leave the machine unattended during operation.
- Do not touch the laser beam when it is on.
- Do not perform engraving on materials of unknown properties.
- Recommended Materials: fabric, glass, metal, stainless steel, aluminum, silver, plastic, etc.
- Use this machine in a horizontal position and make sure it is securely fixed.
- The optimal operating temperature of this machine is 5-28°C. Temperature outside this range may cause the laser to stop working.

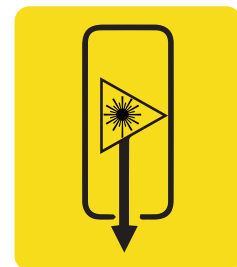

**Warning and indication label**

- The warning and indication label of V5 are placed in areas where potential danger may arise before or during operation.

If the label is damaged or missing, please replace it immediately. You can use the following template to copy and print the label you need.

## 5. Assembly Instructions



1. Place all components on the table.

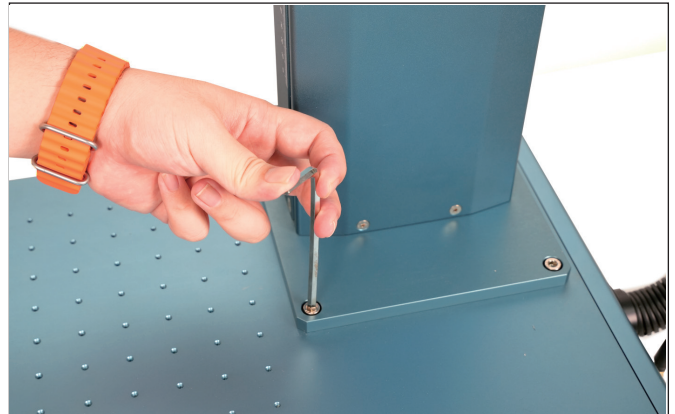

2. Install the lifting column to the base using four screws.



3. Place the laser module on the lifting column. Position two mini levels, one on the base and one on the laser module, and ensure they are parallel. Then, tighten the four screws on the laser module.

( 1 For assisted positioning: When installing the laser head, the assisted positioning indicator dropping signifies correct alignment.

2 Adjust the front-to-back angle of the laser head to ensure that the two mini levels remain parallel.)

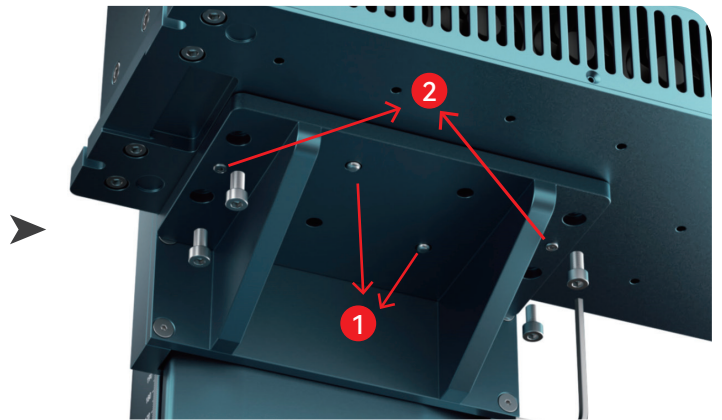

4. Connect all V5 cables.



5. Insert the USB security dongle and power cable, and connect the data cable to the computer.

## 6. Machine Startup & Focusing



1. Turn on the machine power.

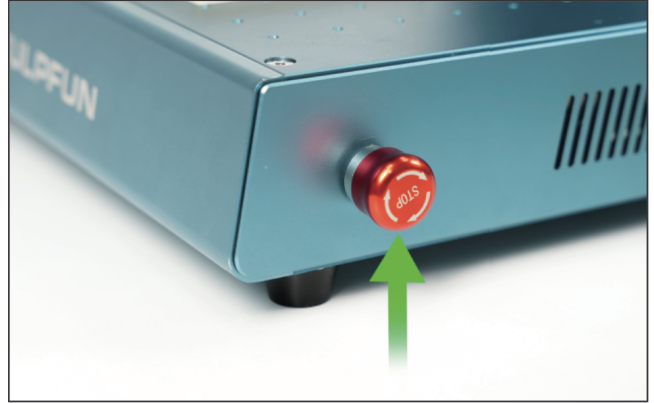

2. Rotary Emergency Stop Switch.



3. Switch on the laser power.

(The laser power indicator will alternately flash blue and green. After about 1–2 minutes, the indicator will turn to a steady green, indicating that the laser is ready for operation.)

**Note:** Please make sure the laser power button is switched ON.



4. Remove the lens protection cover. Place the material on the baseplate, and adjust the engraving position according to the corresponding lens.



5. Using the 150 mm field lens as an example, press the focus indicator button.



6. Hold the lifting button until the two light spots overlap. At this point, you can install the software and prepare for engraving.

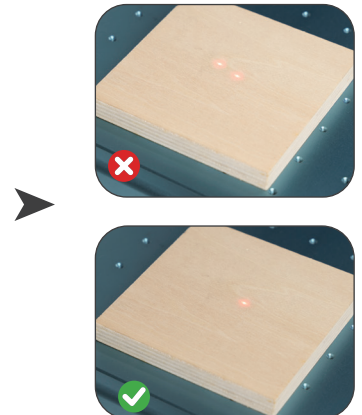

# 7. SGD Software Guide

## Software Installation

U Disk Includes: V5 User Manual, SGD Software, Driver, V5 Calibration Parameters

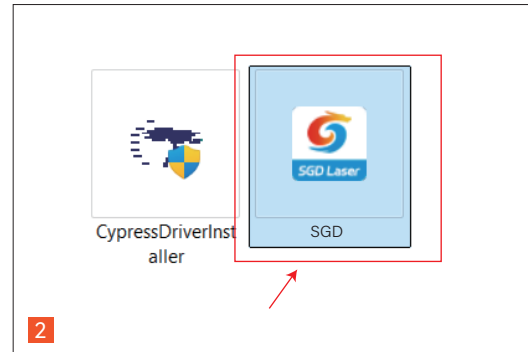
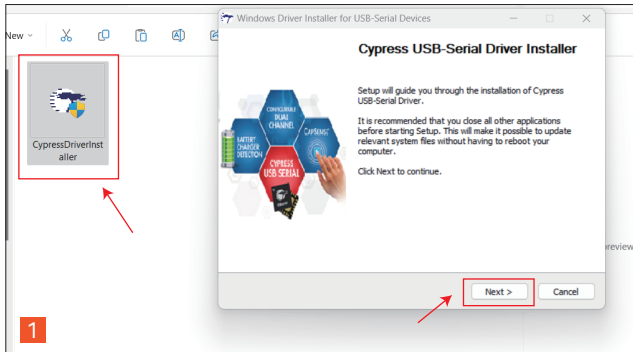

1. For Windows systems, a driver installation is required. Open the included USB drive, locate “CypressDriverInstaller.exe”, and double-click to run the file. Follow the prompts to complete the driver installation.
2. Open the USB drive and locate the SGD laser software. Run the installer to complete the installation.

## Interface Introduction

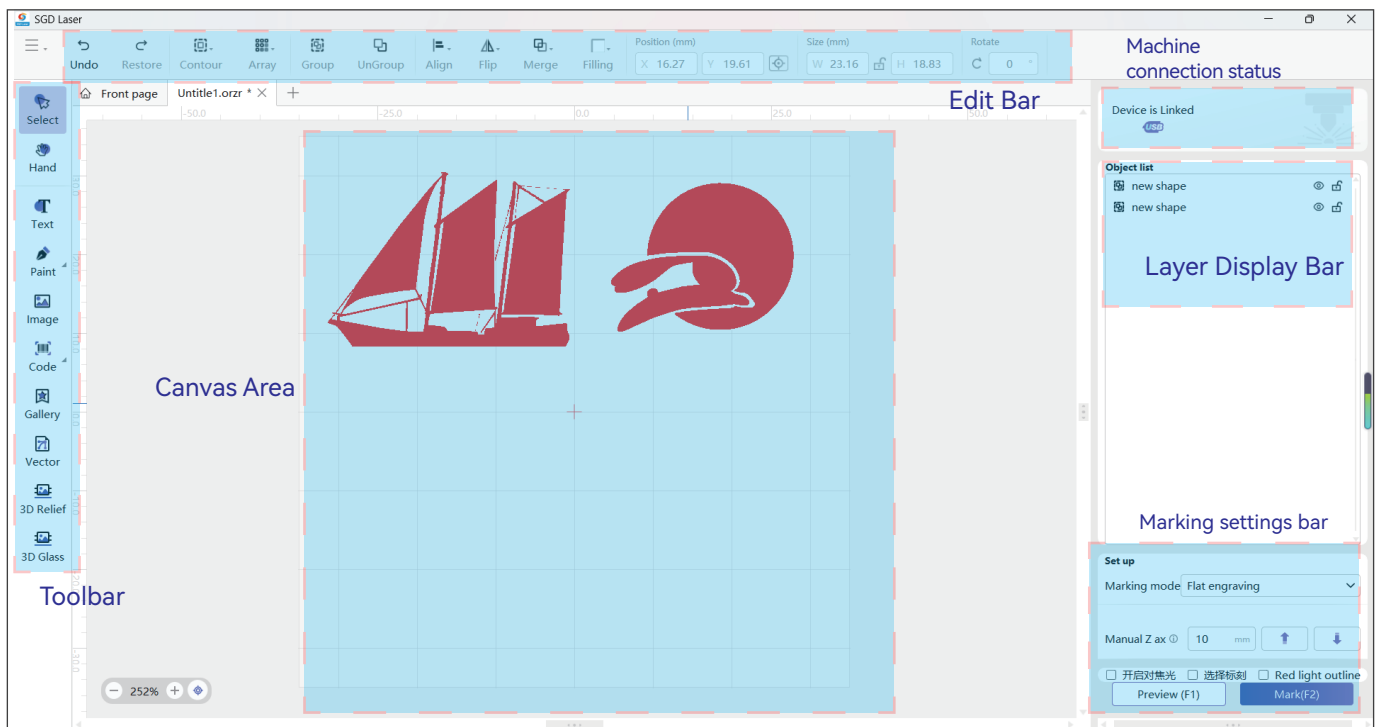

**Caution—use of controls or adjustments or performance of procedures other than those specified herein may result in hazardous radiation exposure.**

Flat Engraving—Example with 150mm Field Lens  
(150mm field lens pre-installed, and the software default parameters correspond to this lens.)

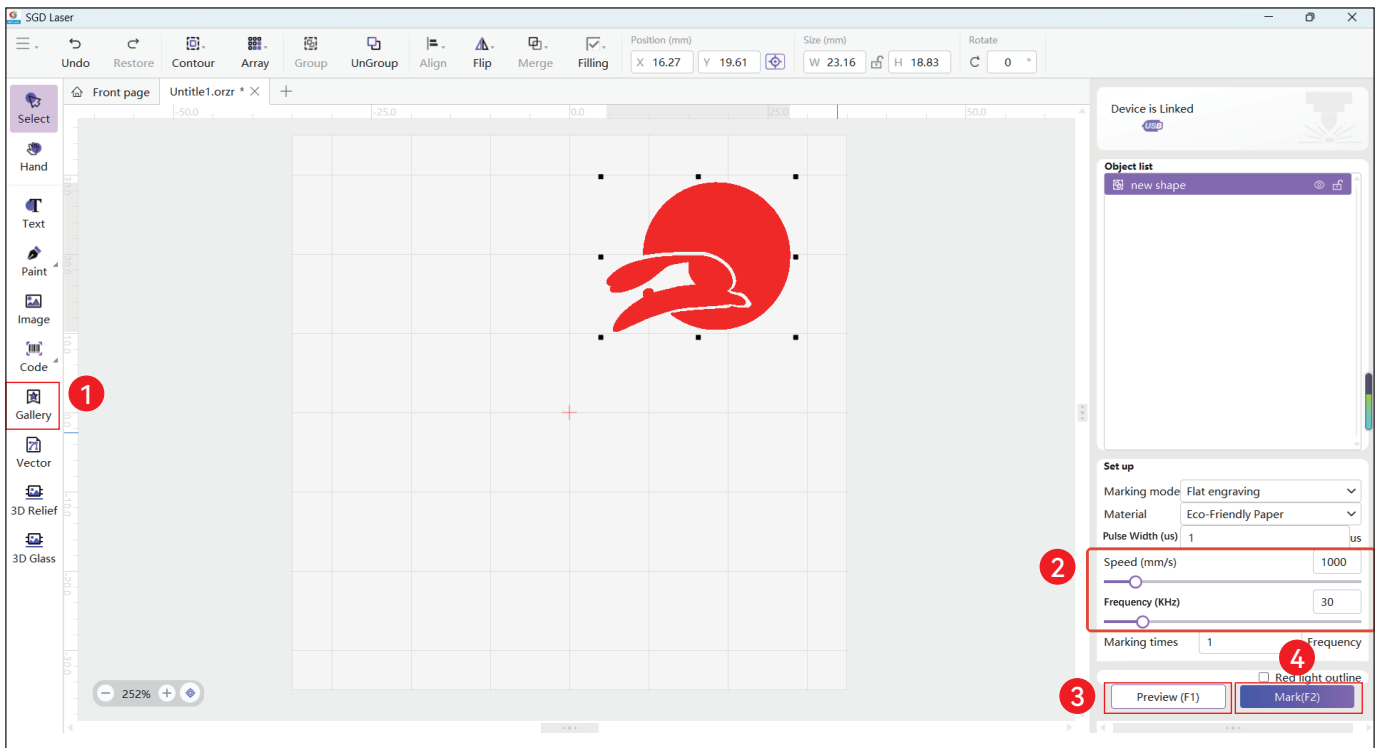

1. Place the material on the laser baseplate, adjust the focus (see p.2 for reference).
2. Import the file into SGD **1**, and set the engraving parameters. **2**
3. Click 'Frame' **3**, ensure the engraving position is correctly aligned with the material.
4. After confirming the position, click 'Engrave' **4**, and wait for the process to complete.

**Note: The above parameters are based on tests conducted under laboratory conditions and are provided for reference only. Parameters may vary depending on the material being used.**

Crystal Subsurface Engraving (Device parameters are preset according to the supplied crystal.)  
— 70 mm Field Lens (only supported with the 70 mm field lens)



1. Replace the 150mm lens with a 70mm lens.

**Note:**

**Be sure to remove the protective cover from the field lens to avoid damaging the galvanometer during installation.**

2. Press the 70mm focusing button on the laser.

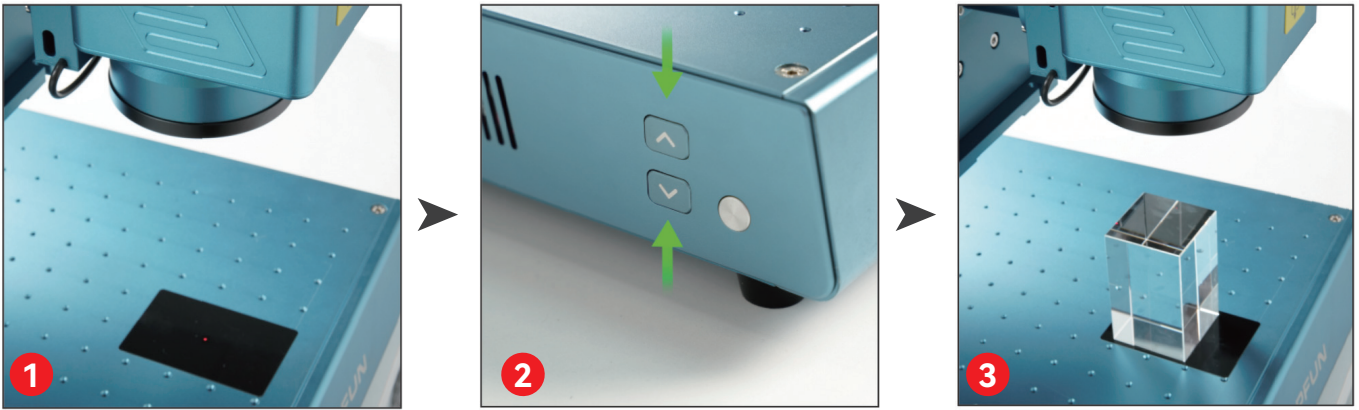

3. Place the focusing sheet on the platform. Press and hold the machine's lift button until the two points align. Finally, place the crystal material.

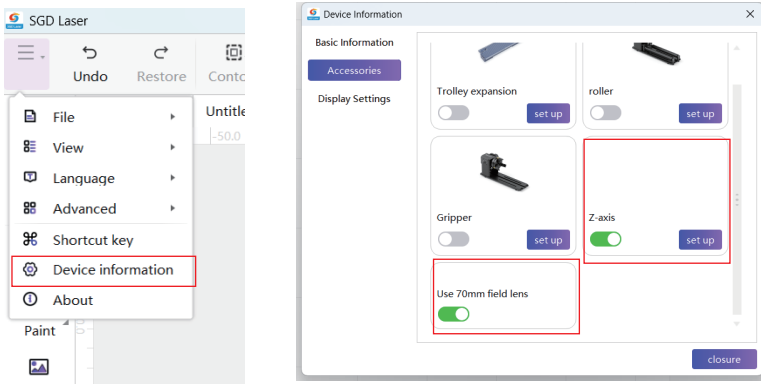

4. Click 'Device Information', turn on the 'Z-axis' and '70mm' switches.

**Note: When using the 70mm lens, turn on the "70mm" switch. For the 150mm lens, turn off this switch.**



5. **1** Click '3D Glass'
- 2** Import the STP model file.
- 3** Set the model view to front.
- 4** Rotate the model to a 90° angle.
- 5** Adjust the parameters according to the crystal size.
- 6** Scale the model to fit inside the crystal.

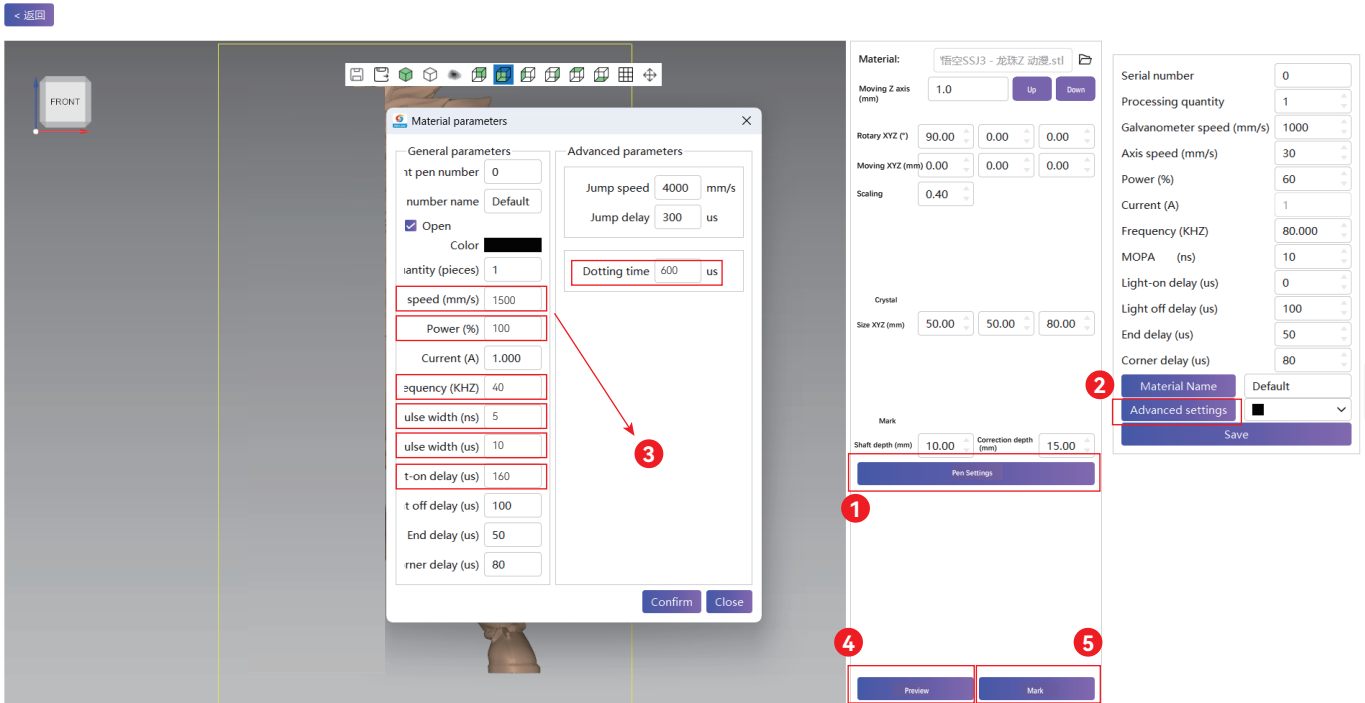

6. **1** In the software, click 'Pen Settings'.
- 2** Click 'Advanced settings'.
- 3** Adjust the parameters in the three red boxes.
- 4** Click "Preview" to check the engraving position.  
(You can place a piece of white paper under the crystal to better see the engraving position.)
- 5** Click 'Engrave' to start the machine.  
It will run until the engraving is complete.

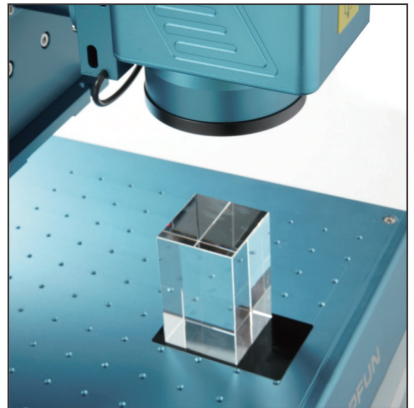

**Note: The above parameters are based on tests conducted under laboratory conditions and are provided for reference only.  
Parameters may vary depending on the material being used.**

## Wood Relief Engraving — 150mm Field Lens Recommended

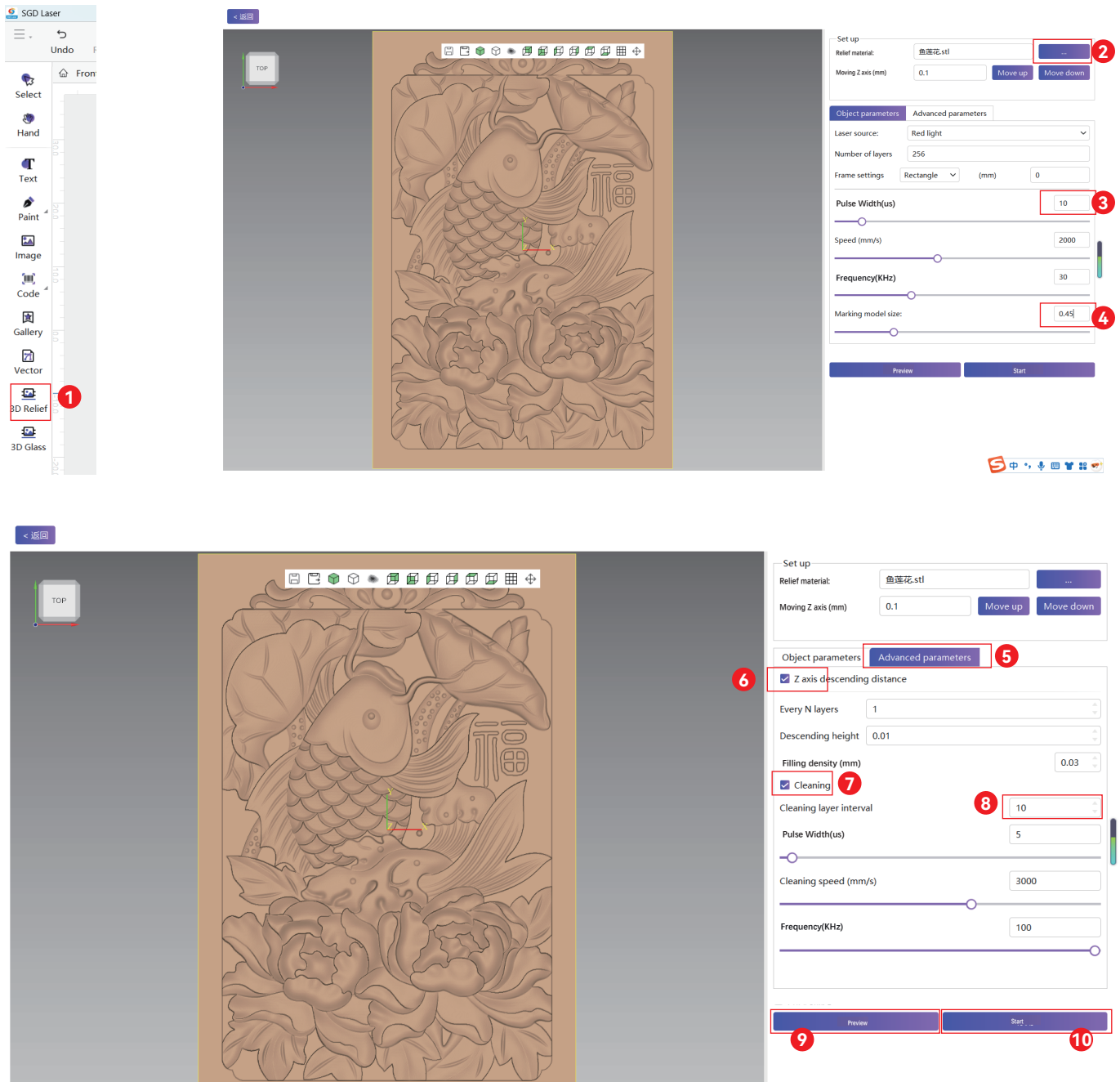

- 1 In the software, click '3D Relief'.
- 2 Import the STP model file.
- 3 Adjust the engraving parameters.
- 4 Adjust the engraving size.
- 5 Click 'Advanced Parameters'.
- 6 Enable 'Z-axis Descending Distance'.
- 7 Enable 'Cleaning'.
- 8 Set the parameters.
- 9 Click 'Preview' to check the engraving position.
- 10 Click "Engrave" to start the machine.

It will run until the engraving is complete.

**Note:**  
The relief function supports relief carving on wood only.

## 7. LightBurn Operation Tutorial (For macOS — Separate Purchase Required)

1. Scan the QR code or visit the LightBurn official website to download and install LightBurn. (Note: LightBurn version Pro 2.0 or above is required; a 30-day trial is available.)



QR Code



2. Turn on the machine and connect it to the computer. In LightBurn, import the bundle by locating the V5 configuration file '**V5 LightBurn Bundle.lbzip**' included on the USB drive. Check both '70mm' and '150mm', then click 'Import'.

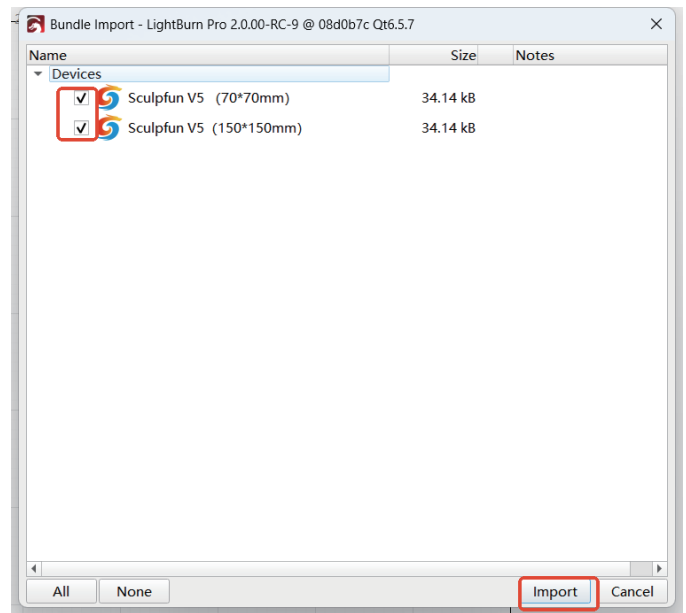
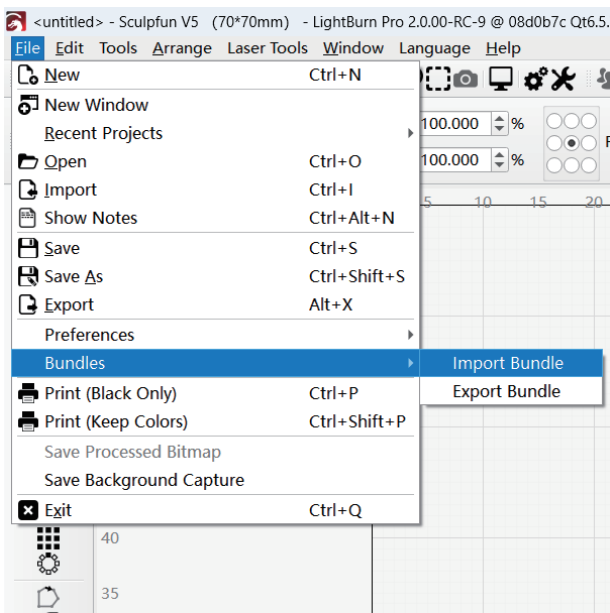

3. In LightBurn, select the 70mm configuration file. In Device Settings, fill in the corresponding galvo and basic settings as shown in the figure, then configure the port and laser settings.

(Note: Parameters may vary for each machine. Refer to the 70mm screenshot on the USB drive for your specific machine.)

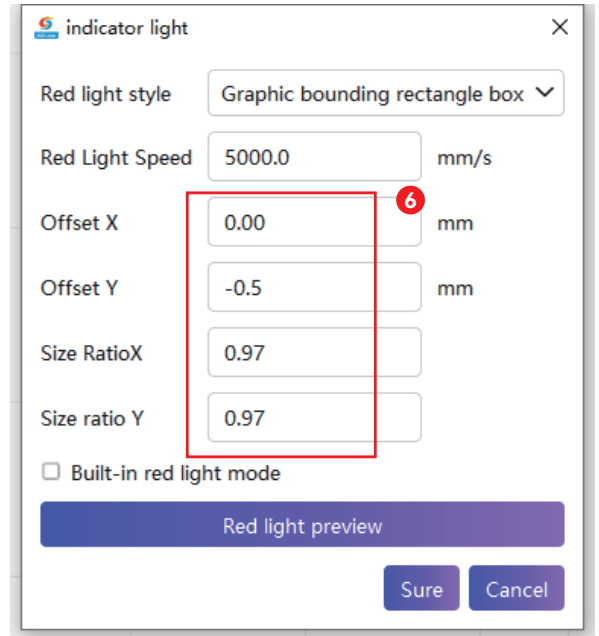
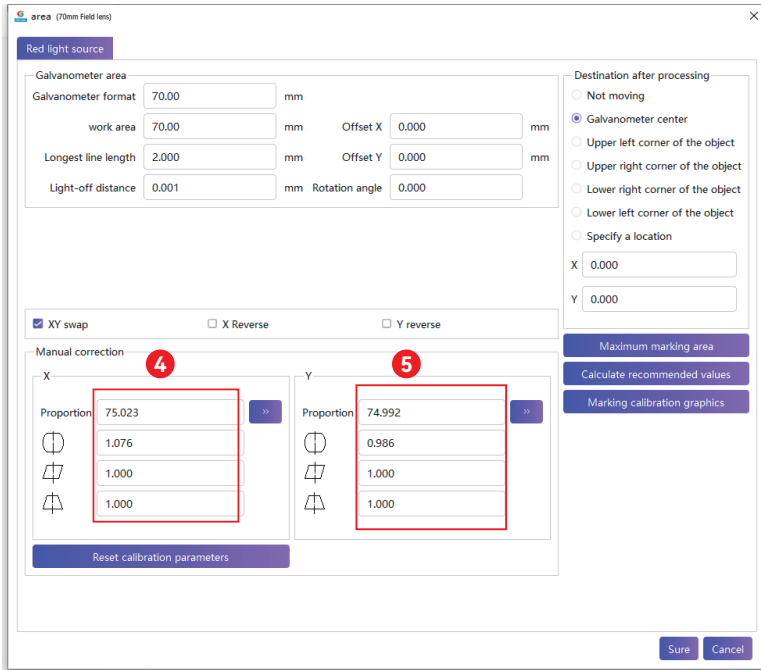
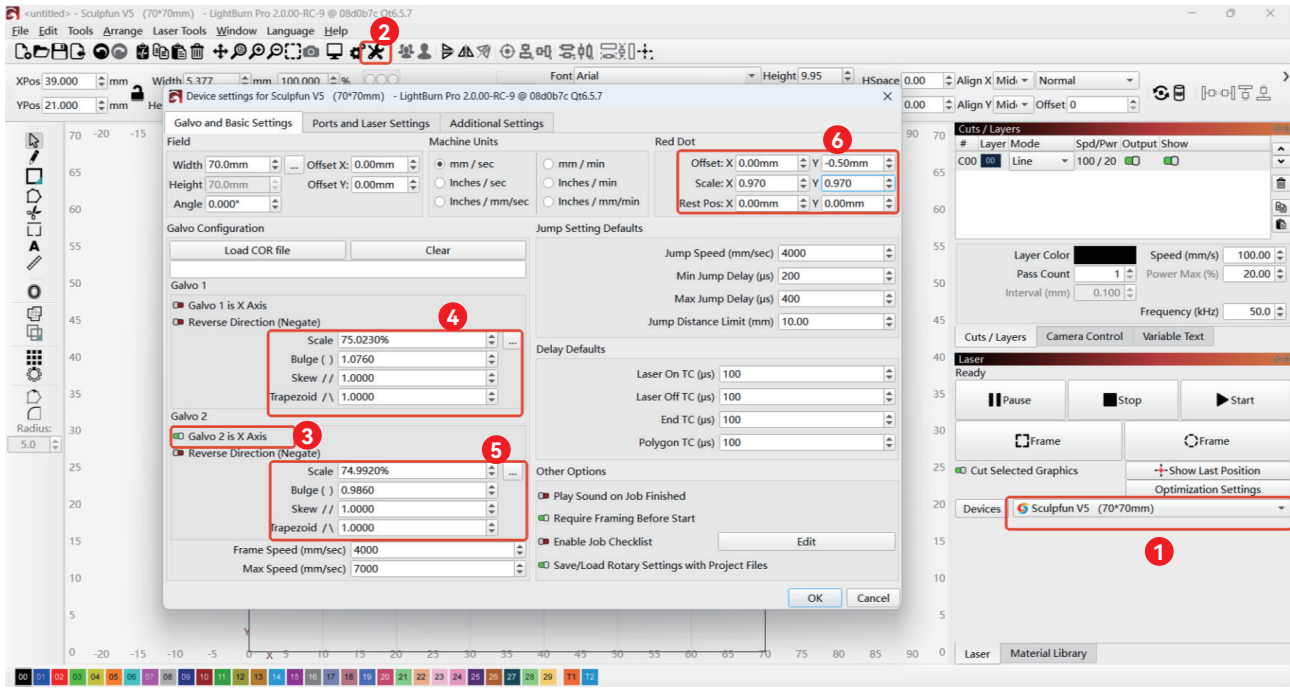

(Example screenshot of 70mm settings on the USB drive  
 — enter the parameters into the corresponding fields in LightBurn.)

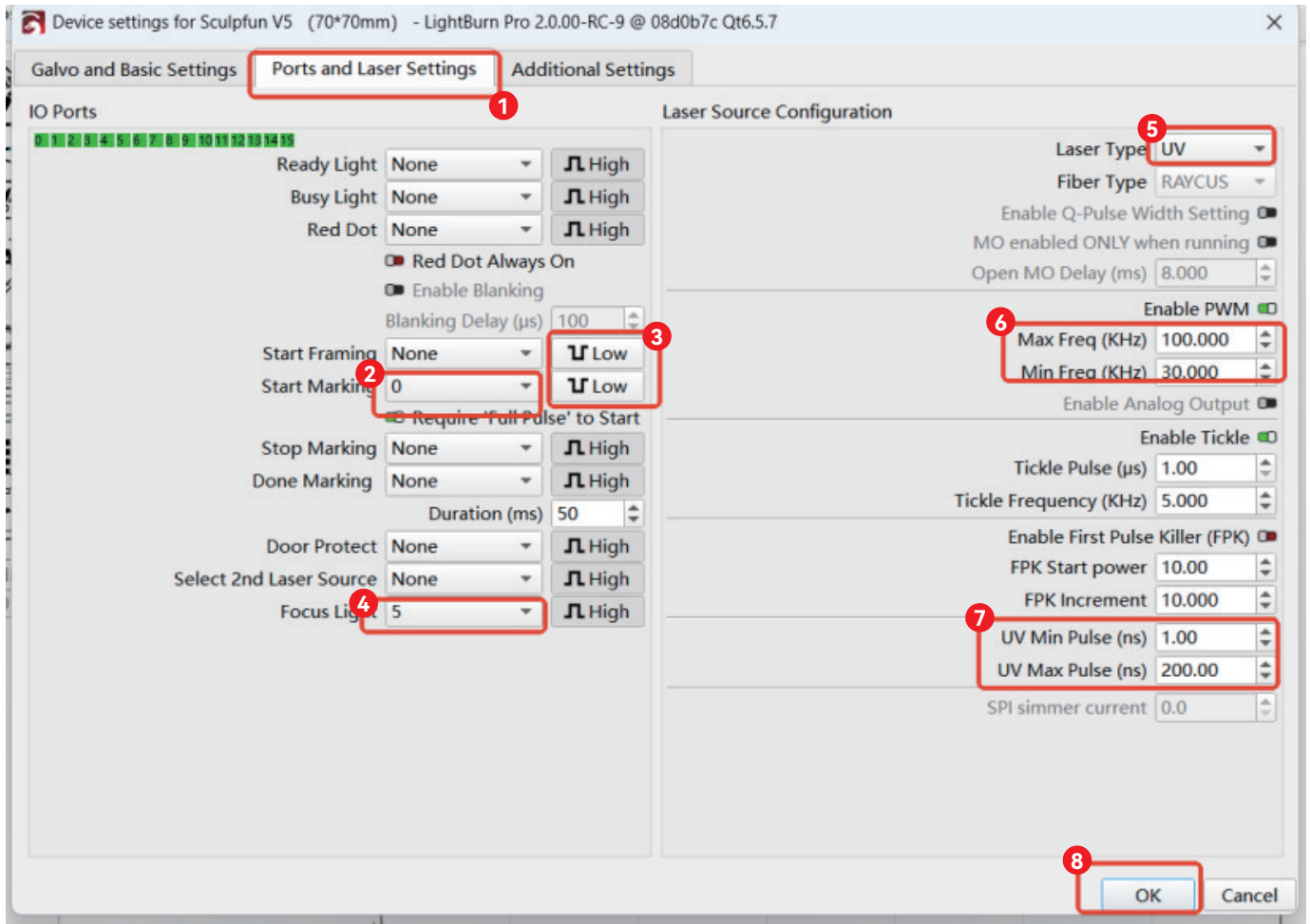

(Adjust the parameters in “Ports and Laser Settings” according to the above values.)

4. In LightBurn, select the 150mm configuration file. In Device Settings, fill in the corresponding galvo and basic settings as shown in the figure, then configure the port and laser settings. (Note: Parameters may vary for each machine. Refer to the 150mm screenshot on the USB drive for your specific machine.)

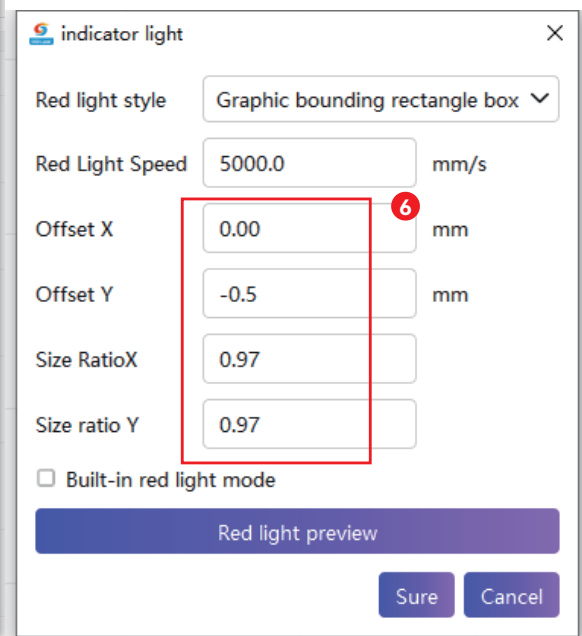
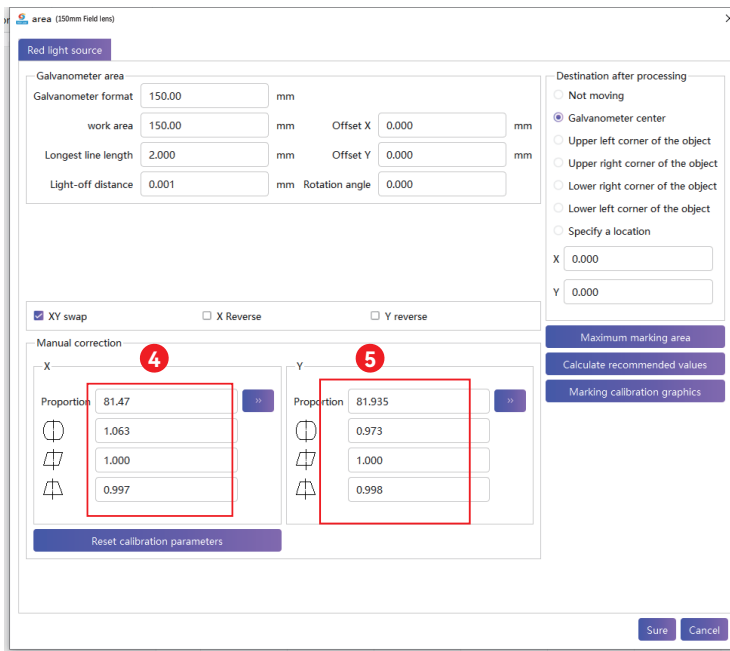
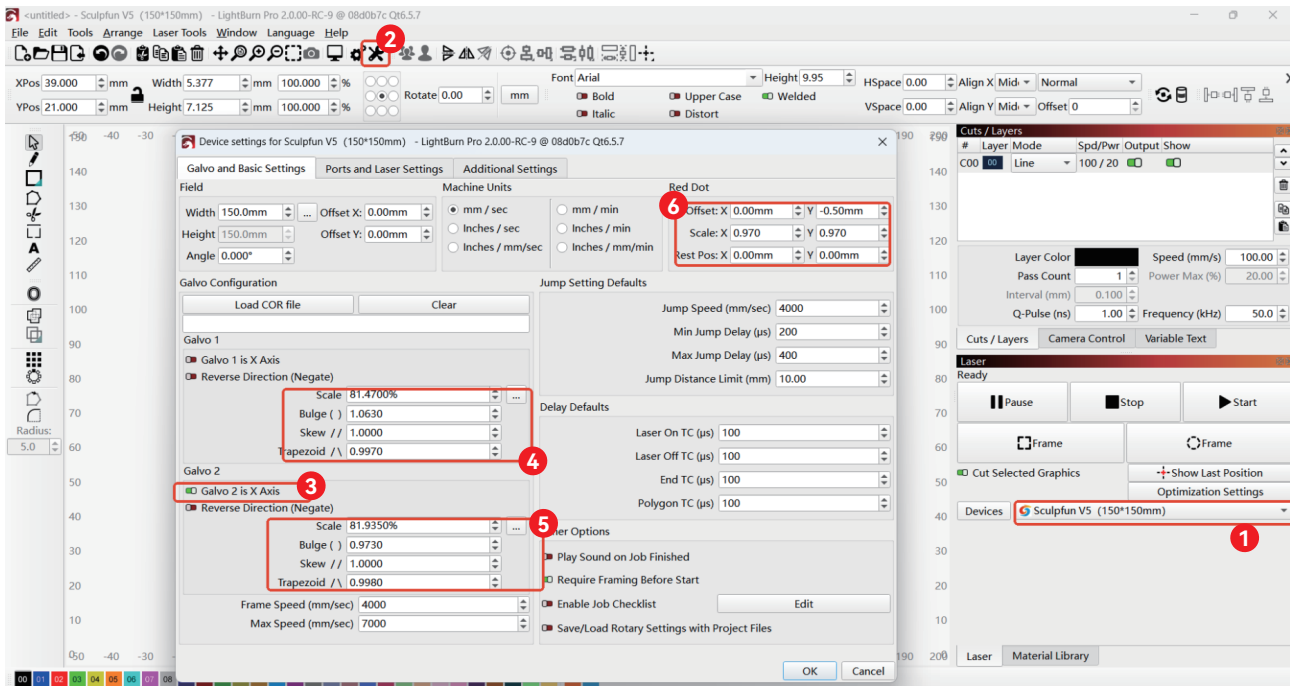

(Example screenshot of 150mm settings on the USB drive  
 — enter the parameters into the corresponding fields in LightBurn.)

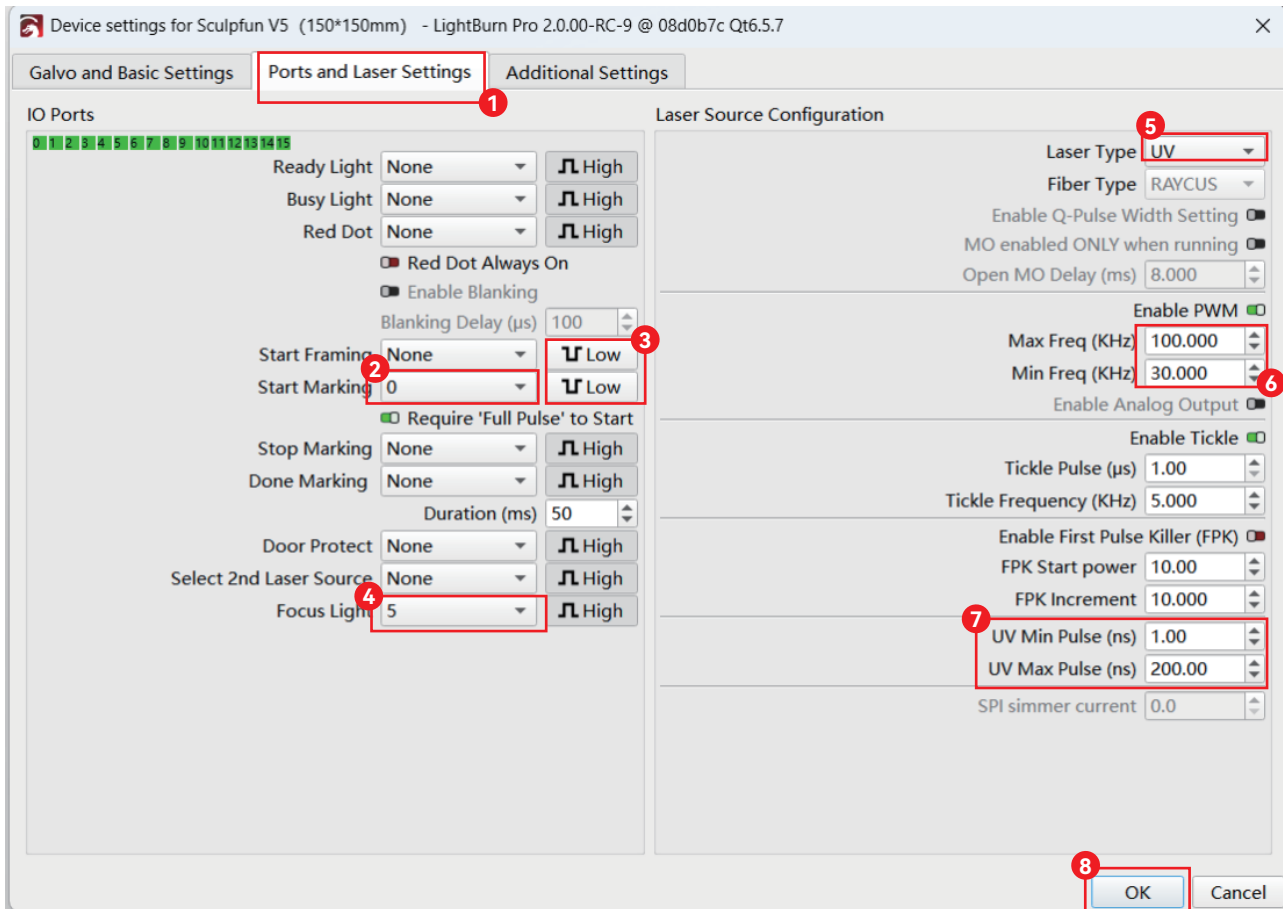

(Adjust the parameters in “Ports and Laser Settings” according to the above values.)

# LightBurn User Guide — Using the 70mm Lens as an Example

(The 150mm Lens is configured in the same way)

- 1 Select the device parameters corresponding to the field lens.
- 2 Import the engraving file.
- 3 Set the engraving parameters according to the material.
- 4 After completing the machine focusing, click 'Start'.
- 5 Check whether the engraving position is correctly aligned on the material.
- 5 Finally, click 'Start' to begin engraving.

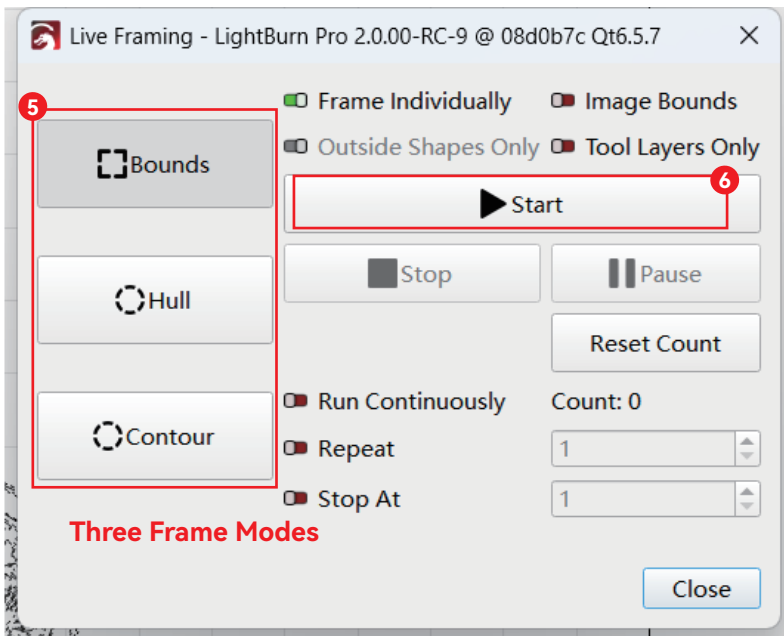
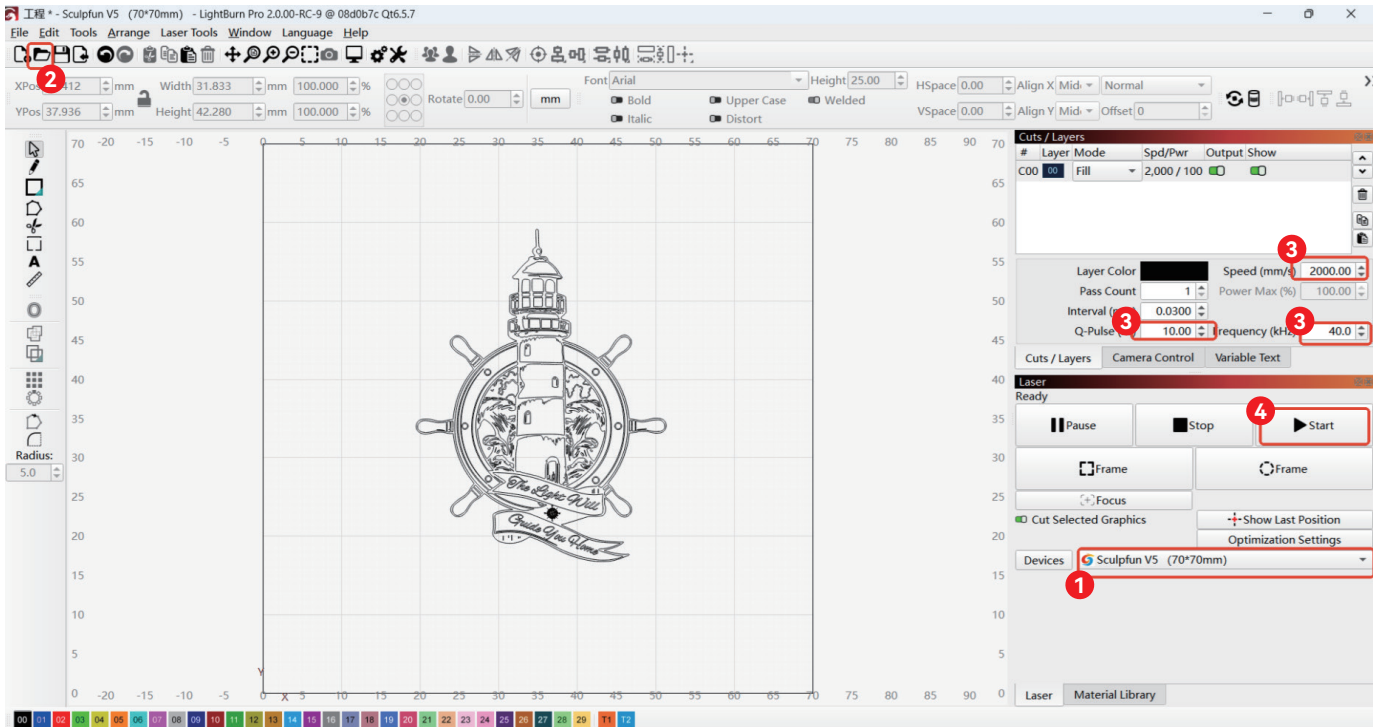

## 8. FAQ

- During engraving, if the engraving content extends beyond the baseplate area. Please reinstall the laser module — the positioning pin is not aligned with the mounting slot.

- After focusing, if no engraving is produced.

It is possible that the focusing assembly has shifted during transportation. Please scan the QR code to watch the maintenance video and adjust the focusing assembly.

- The preview frame does not match the actual engraving position.

The preview red light position needs adjustment. Please scan the QR code to watch the maintenance video and adjust the preview red light module.

- Problems When Using LightBurn.

Currently, the LightBurn version does not support the V5 crystal subsurface engraving or relief engraving functions. If issues occur during flat engraving, please readjust the corresponding parameters or contact us for assistance.

- After engraving, the laser does not work.

The laser power may not be turned on. After switching on the laser power, please allow 1–2 minutes for preheating before starting engraving.

- During engraving, the workpiece is deformed or the machine does not operate.

Please select the corresponding engraving mode in the SGD Laser software.

- Field Lens Selection for the Machine

The machine is shipped with the 150mm lens installed by default. Except for crystal subsurface engraving, the 150mm lens is recommended for all other applications. After switching lenses, please ensure the corresponding software parameters are also adjusted.

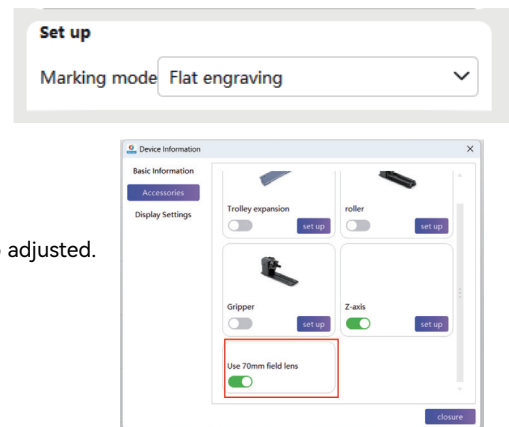

## 9. Machine Maintenance

### 1. Maintenance Overview

Unless otherwise specified, adjustments and maintenance of this equipment should only be performed after turning off the power and disconnecting the power supply. Only trained personnel with professional skills are permitted to modify or disassemble this equipment.

**Note: Unauthorized disassembly will void the warranty.**

### 2. Regular Maintenance

Always keep the workspace clean and free of dust.

Ensure the machine is completely powered off when not in use.

When not in use, cover the optical lens. After use, clean the work surface with a cloth moistened with hand sanitizer containing over 75%. Do not use abrasive or corrosive cleaners, sprays, or excessive water. Ensure the surface is completely dry before the next use.

When using a vacuum cleaner to remove dust from the machine vents, always use the lowest power setting to avoid damaging internal components.

Any other maintenance work must be performed by trained professionals.

Do not attempt repairs or replace components yourself.



If focusing or preview frame alignment is inaccurate:  
Please scan the QR code to watch the instructional video.

## 10. After-sales Service & Warranty Terms

### After-sales Service

If you encounter any issues with your machine, please contact us. We will respond as soon as possible.

E-mail: [support@sculpfun.com](mailto:support@sculpfun.com)

### Warranty Terms

The complete machine and key components are covered by a one-year warranty, while functional parts are covered for three months. Warranty service begins from the date of receipt. For any product that has been repaired or replaced, Sculpfun provides the remaining warranty period of the original product or 30 days of warranty after replacement.

The warranty does not cover issues related to processing quality caused by user operation, materials used, or the processing environment.

## 11. Disclaimer

- This product is a laser marking device. Please scan the QR code in the manual to access the full User Manual as well as the latest instructions and warnings. All information in this material has been carefully reviewed. If there are any typographical errors or misunderstandings, please contact us. Technical improvements to the product (if any) will be incorporated into new manuals without additional notice.
- In case of machine issues or malfunctions, please provide the original marking file, marking software configuration parameters, operating system information, a video of the marking process, and operation steps. This information will help SCULPFUN provide timely troubleshooting guidance and after-sales service.
- SCULPFUN is not responsible for any losses resulting from the user's failure to follow the instructions in this manual. Users are strictly prohibited from disassembling the machine or laser without guidance from our technical staff. Any damage caused by unauthorized disassembly will be the responsibility of the user.
- SCULPFUN reserves the final right of interpretation of this document, in compliance with applicable laws. SCULPFUN also reserves the right to update, modify, or discontinue these terms without prior notice.



**E-mail**

[support@sculpfun.com](mailto:support@sculpfun.com)

**Website**

[sculpfun.com](http://sculpfun.com)