

Quick Start Guide



www.longer3d.com



RAY5 Unboxing Video

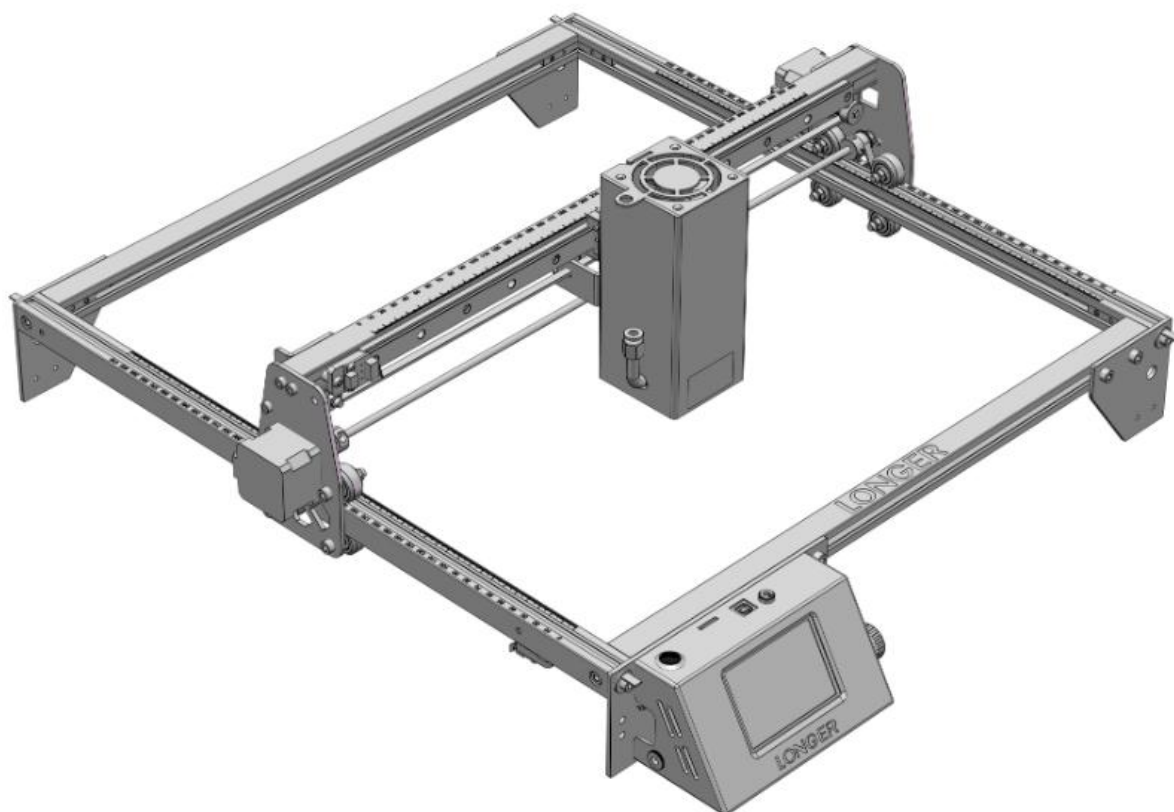

LONGER LASER ENGRAVER Ray5 40W

Thank you for choosing our products.
Please read this manual carefully before use.

Please reference more details on digital manual in TF card about the operation of
Laser Engraver and installation of LaserGRBL or LightBurn.

MORE INFORMATION ▼



Support Email : support@longer.net



Facebook ID: Longer Global



Facebook Group: Longer Laser Engraver Official Group



Youtube channel: Longer Official

If you have any question, please feel free to contact us as above.

*Copyright © Shenzhen Longer Technology Co.,Ltd. All Rights Reserved

Dear customer,

Thank you for choosing LONGER products Ray5 40W.

Maybe you are familiar with the engraving machine or have bought a similar engraving machine before, we still highly recommend that you read this manual carefully. The installation techniques and precautions in this manual can help you avoid any unnecessary damage or frustration.

More information please refer to:

1. Please contact us via email: support@longer.net.

2. Facebook page and YouTube channel as shown below.

Facebook Group: [Longer Laser Engraver Official Group](#)

YouTube Channel: Official

Contents

A. Safety Precautions	1
B. Product Information	8
(1) Specifications	8
(2) Components Introduction	9
(3) Packing List	10
(4) Machine assembly	11
C. Machine Operation	16
(1) Focusing the Laser Module	16
(2) Power On	17
(3) Touch Screen Operation	17
(4) Wi-Fi Control operation	23
(5) LaserGRBL Software Operation	24
(6) LightBurn Software Operation	26
(7) Firmware Upgrading	31
(8) APP Operation	33
D.FAQ.....	49
Question 1: Are there recommended engraving and cutting parameters?	49
Question 2: The engraved pattern appears vibration, or is not closed?	49
Question 3: How about the warranty policy?	49
Question 4: How to maintain Ray5 laser module?	52
Question 5: How to solve alarm 2 error or hard limit?	53
Question 6: How to solve the upload error of the APP?	55

A. Safety Precautions

(1) The Ray5 40W engraves and cuts materials by the means of a high-energy diode laser beam.

The hazards associated with a high-energy diode laser beam include the possibility of fires, generation of hazardous and/or irritating toxic fumes, but more importantly damage to eyes and skin.

(2) Laser engravers are divided into several internationally valid classes based on their performance and the risk of injury. The Ray5 40W falls into the Class IV (Class 4 IEC standard focus on the American FDA classification).

Laser class	Class Definition
Class I	Class I laser radiation is not considered hazardous.
Class IIa	Class IIa laser radiation is not considered hazardous if viewed for any period of time less than or equal to 1×10^3 seconds but is considered a chronic viewing hazard for any period of time greater than 1×10^3 seconds.
Class II	Class II laser radiation is considered a chronic viewing hazard.
Class IIIa	Class IIIa laser radiation is, depending upon the irradiance, either an acute in-trabeam viewing hazard or chronic viewing hazard. If viewed directly with optical instruments, Class IIIa laser radiation is classified as an acute viewing hazard.
Class IIIb	Direct Class IIIb laser radiation is considered an acute hazard to the skin and eyes.
Class IV	Class IV laser radiation is considered an acute hazard to the skin and eyes from both direct and scattered radiation.

The high energy laser beam can cause severe eye damage, including blindness and serious skin burns.

Improper use of the controls and modification of the safety features may cause serious eye injury and burns.

Please wear Personal Protective Equipment (PPE, Safety Glasses are designed to filter specific ranges of laser wavelength. The Ray5 40W Safety Glasses provided are specific for LONGER Laser Module;) when using the machine.

- DO NOT look directly into the laser beam.
- DO NOT aim the laser beam at reflective surfaces.
- DO NOT operate the laser without PPE protection for all persons nearby in the proximity of the Ray5 40W.
- DO NOT allow unsupervised access to the Ray5 40W to children.
- DO NOT allow access near the Ray5 40W to pets.
- DO NOT modify or disable any safety features of the laser system.
- DO NOT touch the high energy laser beam.

(3) We strongly recommend placing the machine in a well-ventilated room, and at the same time, the door of the room has a sealing effect, and the windows have curtains, to effectively avoid looking directly at the laser beam and some smoke and steam, Particles, and other highly toxic substances. At the same time,

you can pay attention to the LONGER products (cover) in the follow-up.

(4) The high-energy diode laser beam can produce extremely high temperatures and significant amounts of heat as the substrate material is burned away while engraving and cutting. Some materials are prone to catch fire during cutting operations creating flame, fumes, and smoke.

(5) Although the Ray5 40W has a built-in flame sensor, this technology should NOT be considered 100% accurate and should be seen only as a warning system.

During the working process of Ray5 40W, if a flame is found, the machine will stop the laser and make a sound to indicate abnormal conditions. Please pay attention to the working status of the machine.

during operation to ensure that any flare ups/ flame is properly contained and extinguished.

It is strongly recommended that a Fire Extinguisher should be located within proximity to the Ray5 40W. Extinguishers should be halogen or multi-purpose dry chemical. Alternatively, or in conjunction with the Fire Extinguisher it is recommended a "Fire Extinguisher Ball" is positioned beside the Ray5 40W.

- DO NOT use materials that are highly flammable, explosive or produce toxic by-products.
- DO NOT remove material from the cutting bed before it has cooled.
- DO NOT leave the Ray5 40W operating unattended.
- ALWAYS clean up clutter, debris, and flammable materials in the laser Ray5 40W bed after use.
- ALWAYS keep a properly maintained fire extinguisher nearby.
- DO NOT allow the USB cable to contact with the laser Beam.
- DO NOT allow the 24V power cable to contact with the laser Beam.

(6) During the engraving process of the Ray5 40W laser engraving machine, different materials may produce different pungent odors. Always use Ray5 40W laser engravers in open and well-ventilated areas.

(7) Environmental requirements

Temperature requirement: 10° C~30° C, humidity requirement: 20%~50%, this Ray5 40W laser engravers can work normally within this range; beyond this range, this laser engravers will be unable to achieve the best engraving results.

(8) Below a list of some of the most known hazardous materials that the user SHOULD NOT attempt to engrave or cut on. If a material

is not in this list, do not consider it to be safe to use. Obtain the Safety Data Sheet (SDS) from the material's manufacturer when handling unknown materials.

Material	Reason to avoid engraving / cutting it
PVC (Poly Vinyl Chloride)	PVC will emit Chlorine gas when laser cut, or laser engraved. This toxic gas can ruin the optics and motion control system of the laser engraver, in fact, engraving or cutting PVC is a sure way of voiding the warranty of your laser engraver
Lexan / Thick Poly-carbonate	Lexan not only cuts poorly but it also catches on fire very easily. The window of the laser engraving machine is usually made from polycarbonate because it does a very good job of attracting infrared radiation., which is the frequency of light the engraver uses when cutting and engraving materials. This makes the laser cutter quite ineffective in cutting polycarbonate materials
ABS	ABS melts upon exposure to a laser beam as opposed to vaporizing which would be the ideal reaction needed for laser engraving. Instead of leaving a crisp image, ABS will melt and leave a gooey deposit on the surface.
HDPE	HDPE melts and catches on fire easily upon exposure to a laser beam.
Polystyrene Foam	Only very thin pieces can be laser cut but for the most part, polystyrene catches on fire and melts when exposed to a laser beam
Fiberglass	Fiberglass is made from two materials: glass and epoxy resin. The best method of marking glass is etching while epoxy resin can emit toxic fumes upon laser engraving. These two reasons make fiberglass a bad choice for a laser engraving material
Polypropylene	polypropylene melts and catches on fire easily and then the melted material continues to burn thereby forming pebble-like drips that harden on the surface
Coated Carbon Fiber	Coated carbon fiber emits noxious fumes. Additionally, carbon fiber can be cut albeit with some fraying but this is not the case when it is coated.

(9) The Ray5 40W has built in technology and algorithms to keep its users and the surrounding environment safe. This said it is

important to understand the Ray5 40W is not a toy and should be operated with care and respect.

(10) Important information regarding your Ray5 40W

Ray5 40W use 24V DC power system:

- Never Use a different voltage Power Adapter. The Ray5 40W requires DC 24V 9A.
- When using an alternative Power Adapter, the Voltage should always be 24V, the minimum Amperage output should be 9A. Higher amperage output Power Adapter can be used without risk of damage to your Ray5 40W.
- On inserting the power barrel into your motherboard, it is possible that a small spark is visible. This is NOT hazardous to your machine and is caused by the 24V power inrush. If you prefer to avoid this, connect the power barrel to your motherboard first, then connect your power adapter to the mains electricity plug.
- Once the Ray5 40W detects 24V present you will see the motherboard emit a light red glow on the LED of the Motherboard. This mean the motherboard is powered.
- If when plugging your Power Adapter barrel to your

Motherboard and the Power adapter to mains power a green LED does not turn on, please verify your power adapter is receiving Mains Power.

B. Product Information

(1) Specifications

Machine	
Machine Model	Ray5 40W
Working Area	385 x 385 mm (15.16 x 15.16 in)
Power Adapter Input Voltage (AC)	100-240 V, 50-60 Hz
Power Adapter Output Voltage (DC)	24 V 9A
Power Max Consumption	175 W
Packaging Size	614 x 422 x 132mm(24.17 x 16.61 x 5.2 in)
Packaging Weight	8.2 Kg
Machine Size Assembled	518 x 633x 182mm (20.39 x 24.92 x 7.8 in)
Operating Temperature	10 – 30°C
Laser Module (40W)	
Laser Module Model	Ray5 40W
Laser Technology	Four Diode Laser with FAC
Wavelength	450 - 460 nm
Max Power Input	DC 24V 9A
Optical Power Output	44 - 48 W
Focus Type	50 mm Focal length
Dot Size at Optimal Focus	0.10 x 0.15 mm
Laser Class	FDA Class IV , or Class 4 IEC standard
Applicable Material	Engraving: Plywood, Basswood, Hardwood, Pinewood, Acrylic, Kraft paper, Stainless steel, Aluminum alloy, Ceramics, etc. Cutting: Basswood, Acrylic, Bamboo, Kraft paper, etc.
Software	
Software	LaserGRBL (free), LightBurn (paid)
Operating System	LaserGRBL: Windows Lightburn: Windows, MacOS, Linux
Input Image Format	JPG, PNG, BMP, GIF, SVG, AI, etc.
Connection type	USB cable, Micro SD Card, Wi-Fi

(2) Components Introduction

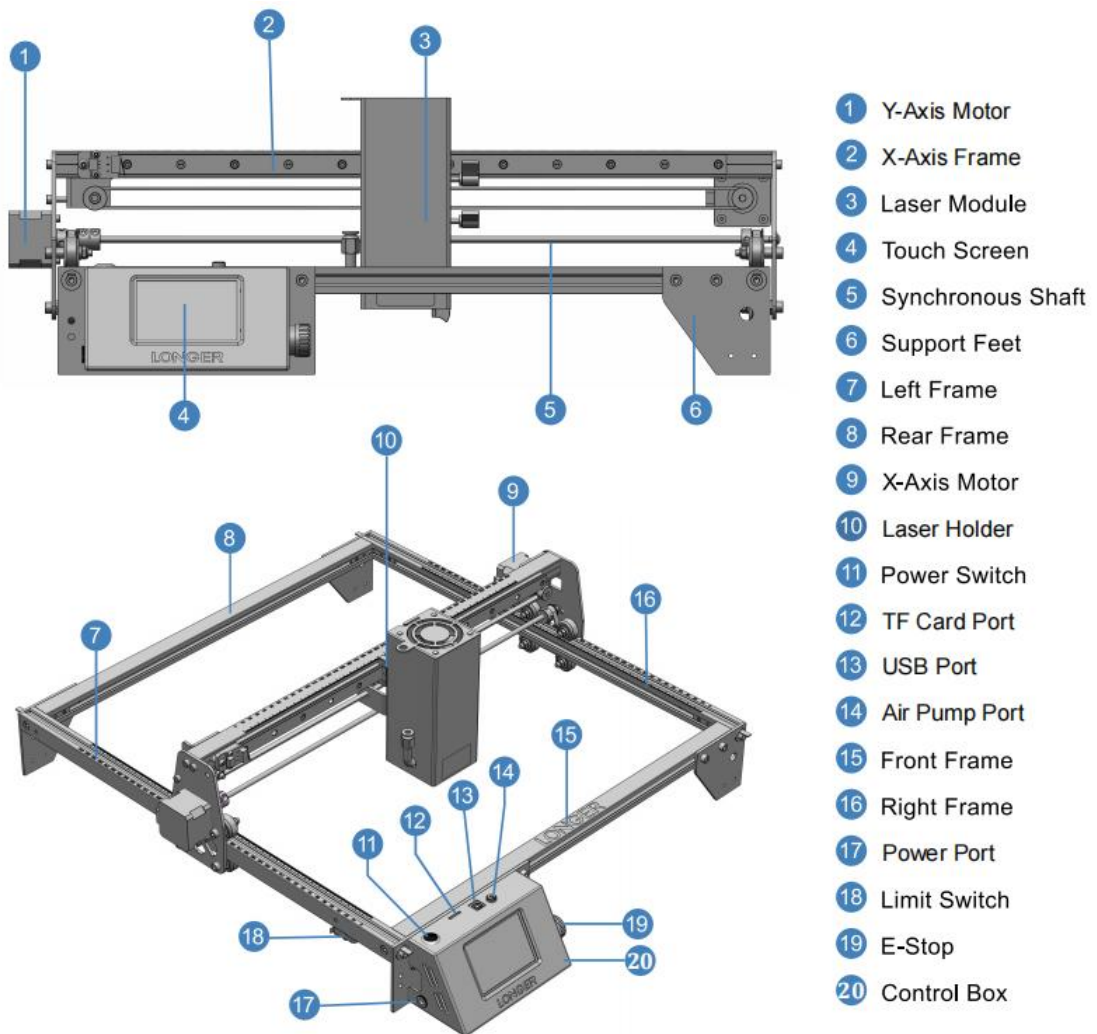

(3) Packing List

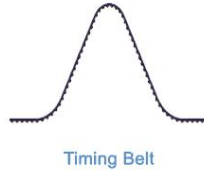
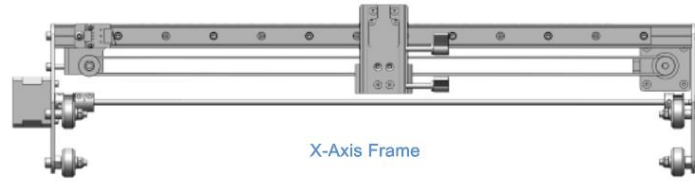

③ Rear Frame



Corner Groove X4

Flat Washer X4



① Front Frame

LONGER

④ Left Frame

② Right Frame

(4) Machine assembly

The machine step-by-step assembly process is described in the document “Ray5 40W Quick Start Guide”. Please follow the guide to assemble machine.

- During the machine assembly, if there is any unclear place, please refer to the video “Ray5 40W Quick Start Guide”.
- Each unit of the engraving machine has been inspected and tested. Therefore, in some cases, very small traces may be left on the profile and the metal shell. These will not affect the quality. It is normal that it does not affect normal engraving. Thank you very much for your understanding.
- Be cautious during assembly as some parts may have sharp edges.
- If you have any questions after receiving the product, please contact our customer service first.

- 1 Place the profiles on a flat table in order, and place four corner grooves into the profiles referring to diagram. ▼

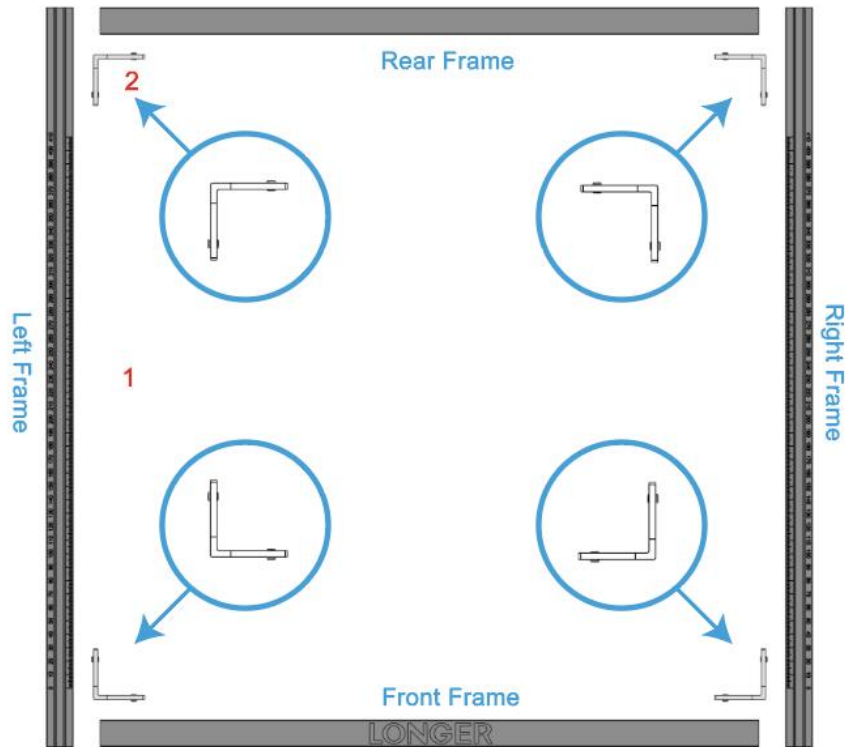

- ▼ Tighten the M5*20 screws into frames.
Tighten the M4 screws on the corner grooves.

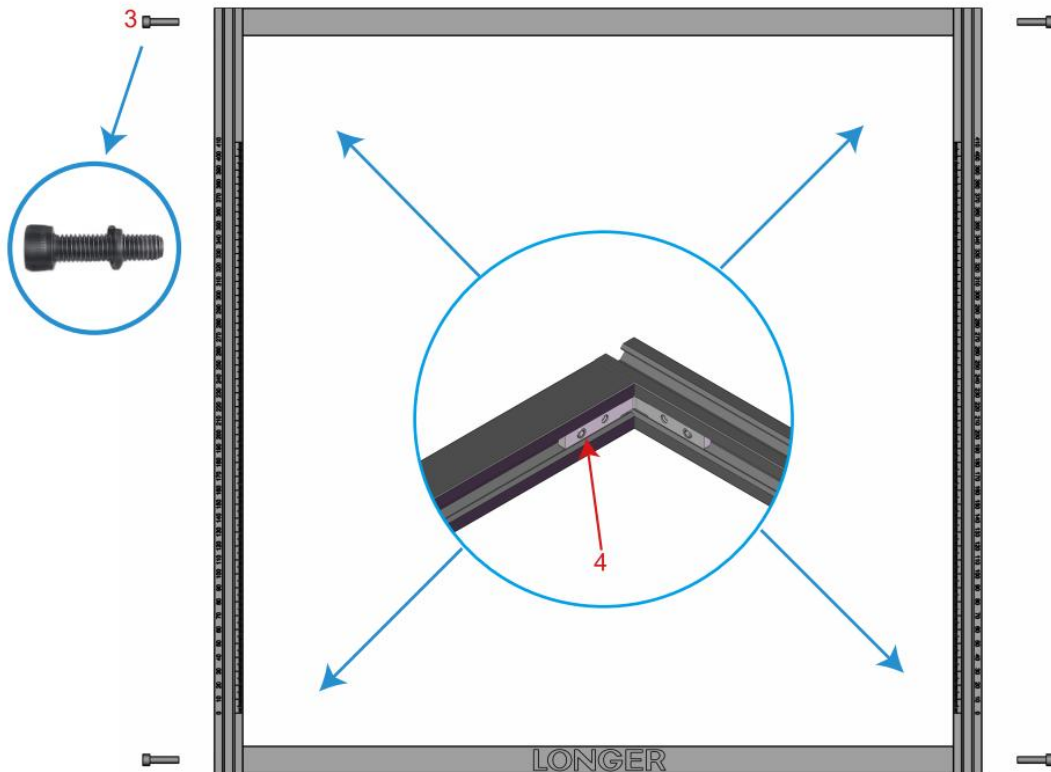

2 Preparation:
X-Axis Frame, and the frame to complete the assembly.

Install the X-Axis Frame in the V-groove of the left and right Frames along the direction of the arrow.

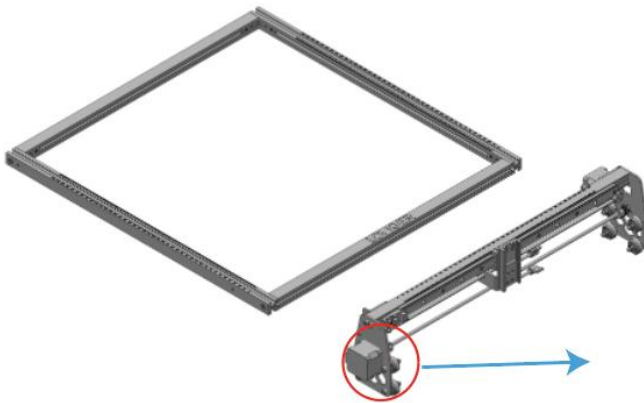
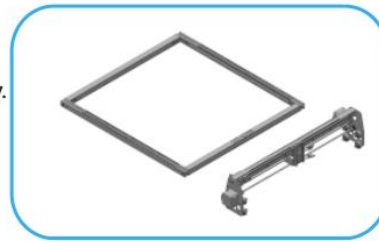

Pay attention to adjusting the eccentric nut to prevent the roller from being damaged by the groove.

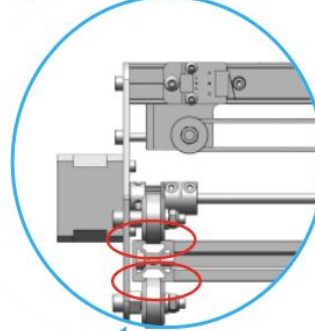

Eccentric nut

3 Preparation:
Preparation: Support feet x3, engraving machine control box, M5*16 hexagon socket cup head screw x7, antenna.

According to the figure, install the supporting foot, the control box of the engraving machine, and the antenna in the corresponding position.

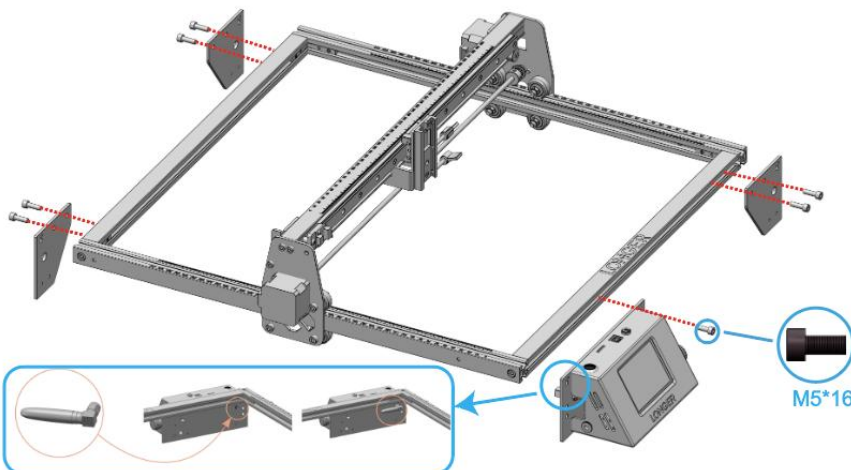
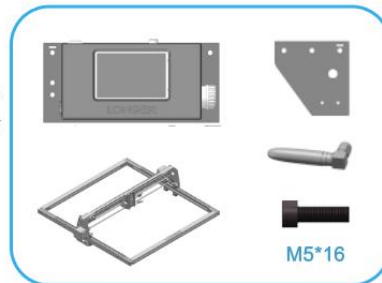

4

Preparation:

Flat washer x4, Timing belt x2, Limit Switch, M5X10 hexagon socket head screw x4.



- Place a timing belt along the red arrow with the tooth face down.
- Put the flat washer on the M5X10 screw, press the timing belt with the flat washer and tighten the screw.
- Tighten the belt by hand, then fix another end of belt in the manner of previous step.
- Fix another belt on left frame in the same way.

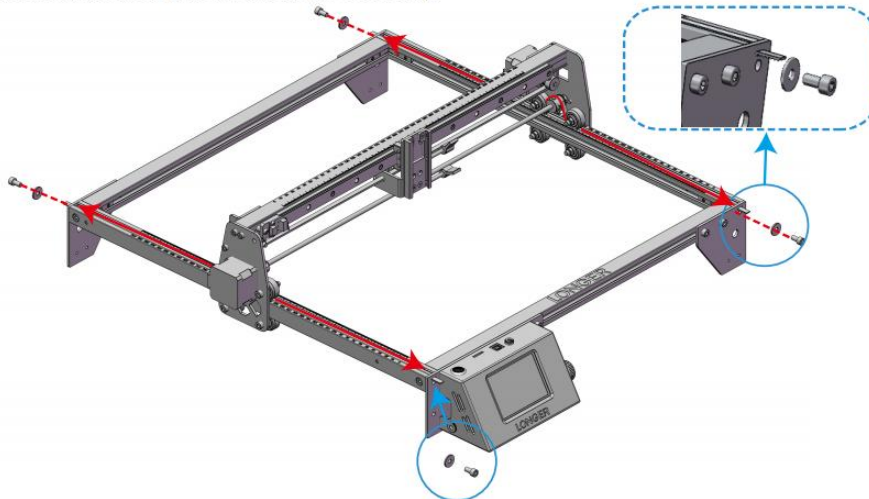

Note: When securing the timing belt, do not allow the screws and flat washers to over-press the timing belt to avoid damaging the timing belt.

- Turn the Ray5 40W engraver over, attach the limit switch to the edge of the label, and fasten it with a hex key allen wrench, then limit switch is about 52mm from the left sheet metal.

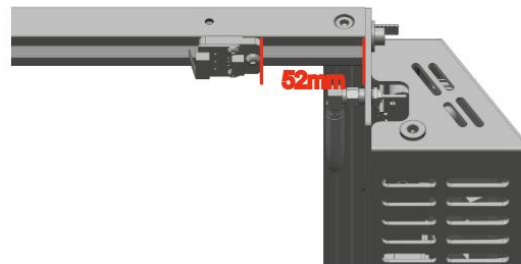

Note: Please install the limit switch attached with label, otherwise it will affect the engraving size or cause the laser head module to collide with the profile when homing.

5

Preparation:

Laser module

First install the laser module on the X-axis frame, then tighten the M4*20 handle screw clockwise to fix the laser module

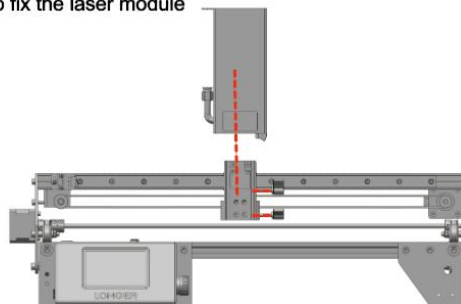

- 6** As shown in the figure, connect the cables of the control box to the motor, limit switch and laser module. Connect one end of the silicone tube to the laser module and the other end to the air pump. Finally, plug the air pump terminal into the control box port.

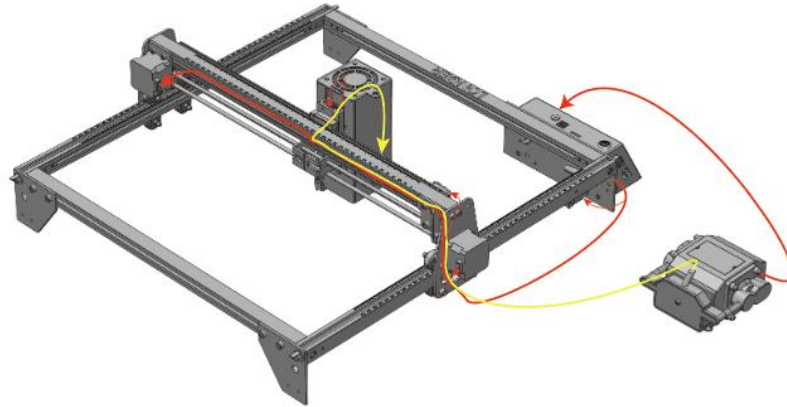

Note: Move the laser module to the upper right corner and use the velcro on the side of the metal plate to secure the cable and silicone tube. Please leave enough cable and silicone tube length to ensure that the laser module can move freely within the maximum engraving range.

- 7** Adjust laser focus:
Pull out the focusing block, loosen the M4*20 handle screw, move the laser module down, tighten the M4*20 handle screw when the bottom of the focusing block touches the plywood, and close the focusing block

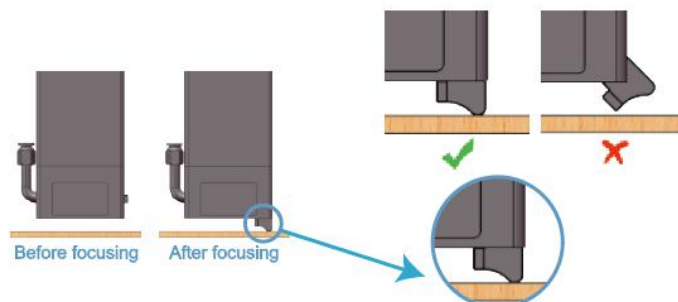

Please reference more details on digital manual in TF card about the operation of Laser Engraver and installation of LaserGRBL or LightBurn.

- * Before using the engraver, please rotate it clockwise to release the emergency stop switch, otherwise the Ray5 40W cannot be powered on normally, **and be careful not to rotate the emergency stop switch counterclockwise to avoid damage.**

C. Machine Operation

(1) Focusing the Laser Module

- a) Place the machine on a flat table and make sure that the machine is stable and will not shake.
- b) Place the wood board to be engraved or cut under the laser.
- c) Pull out the focusing block, loosen the M4*25 handle screw, move the laser module down, tighten the M4*25 handle screw when the bottom of the focusing block touches the plywood, and close the focusing block.

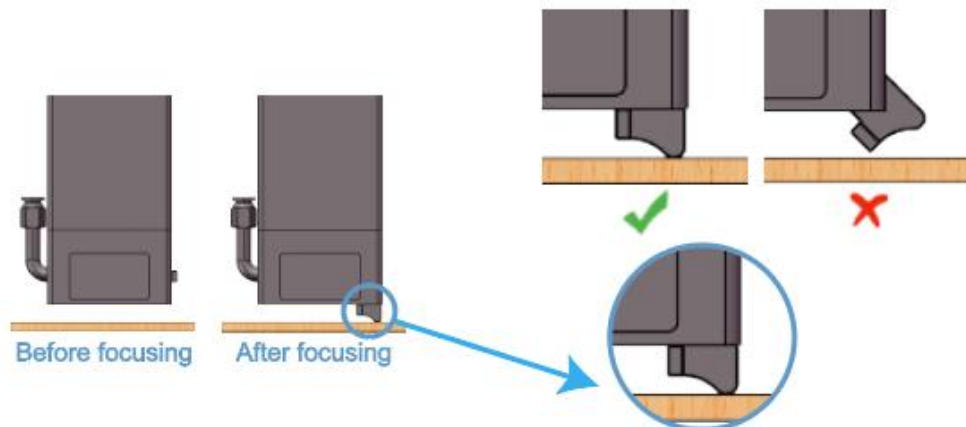

(2) Power On

- a) Find the adapter and power cable and connect them. Please make sure the output of Ray5 40W adapter is DC 24V 9A.
- b) Connect the power cord to the power supply and connect the other end of the adapter to the power port of the motherboard.
- c) Connect the computer and the engraving machine through a USB computer (or insert a Micro SD card).
- d) Turn ON your Ray5 40W by press the power switch (To Turn OFF your Ray5 40W by press the power switch once again.)

(3) Touch Screen Operation

Ray5 40W has a full-color 3.5-inch touch screen with a user-friendly user interface. Engraving and cutting work can be operated with touch screen and SD card.

- a) Home page

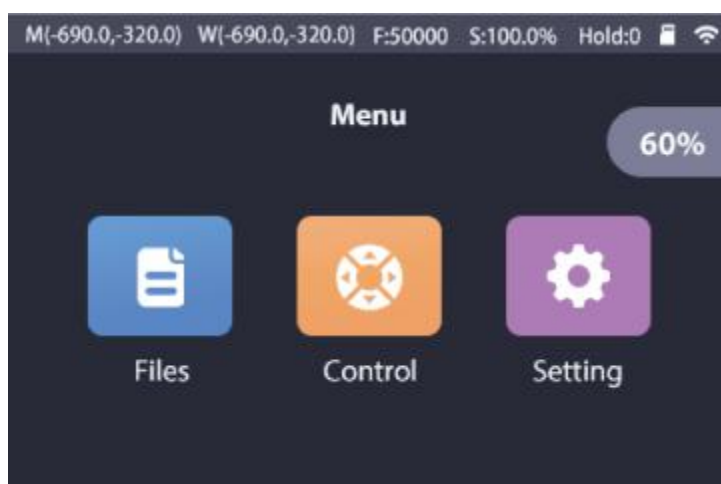

b) Files page

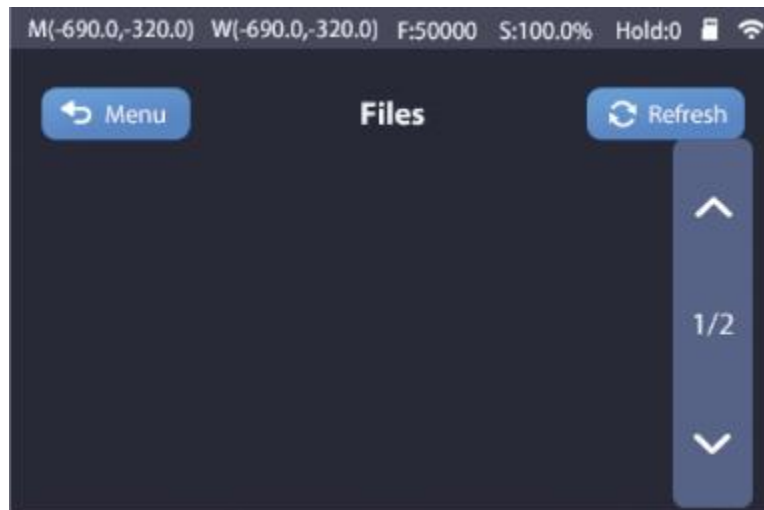

c) File Engraving Preparation Page

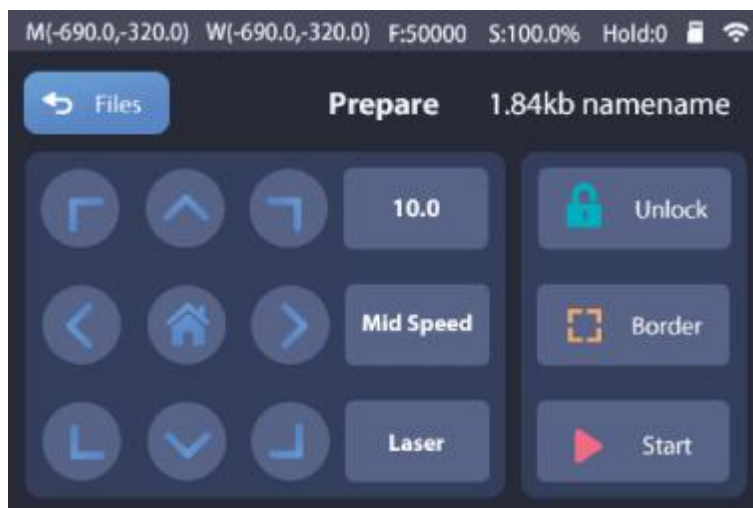

d) Engraving Page

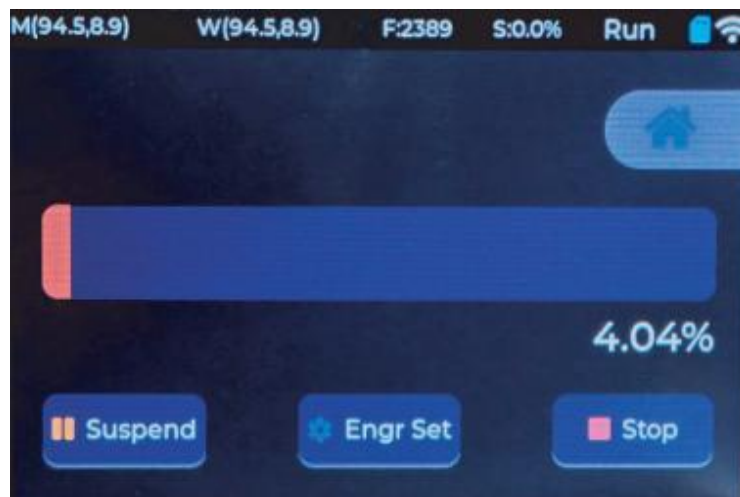

e) Engraving Settings Page



f) Control page



g) Set the laser intensity for scanning borders

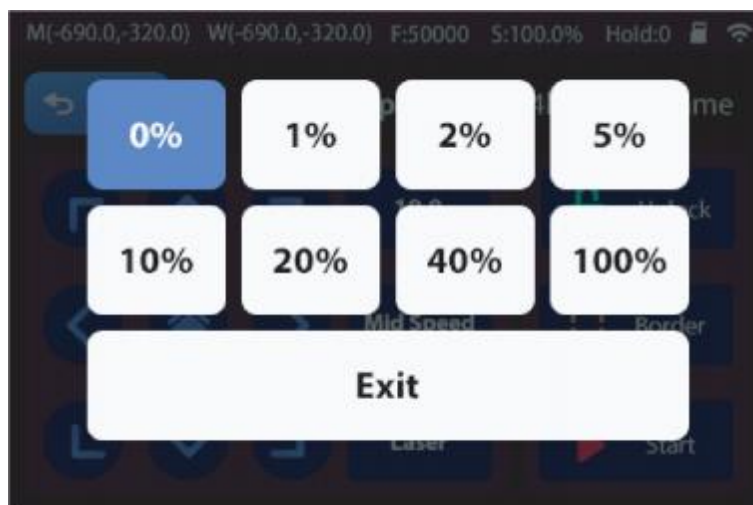

h) Setting page



i) Network page



j) AP Mode Page

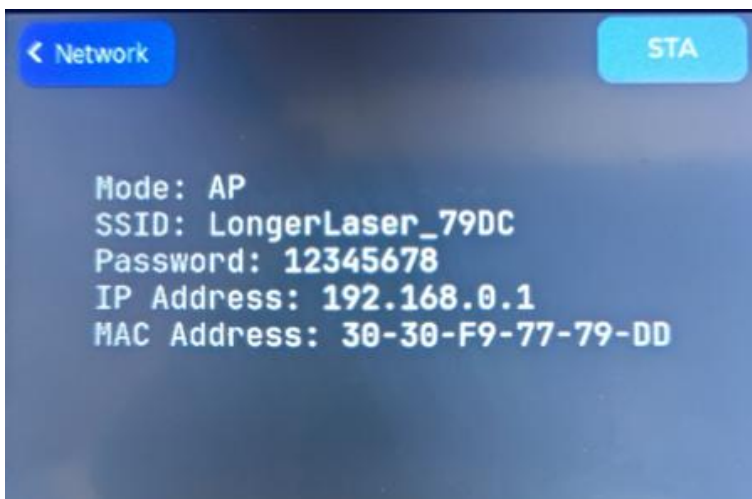

k) STA Mode Page

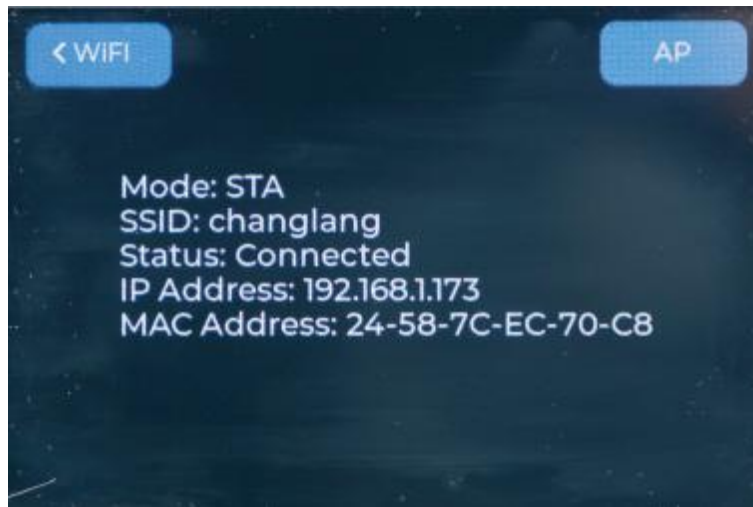

l) Language Page(English, German, French, Italian, Spanish, Portuguese, Japanese, Chinese)



m) Backlit Pages



n) Screen firmware upgrade page

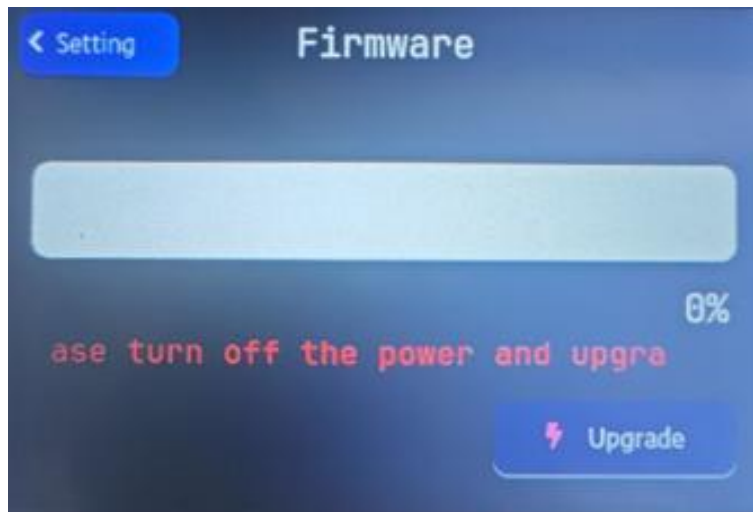

(4) Wi-Fi Control operation

- a) Connect the computer and machine to the same WiFi or hotspot, then obtain the IP address.

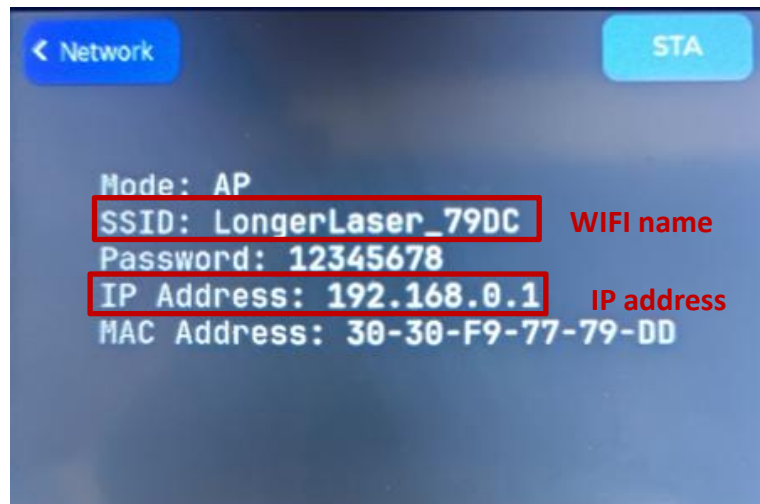

- b) copy it to the browser, enter IP: 8848 in the address bar, and the control interface will pop up.

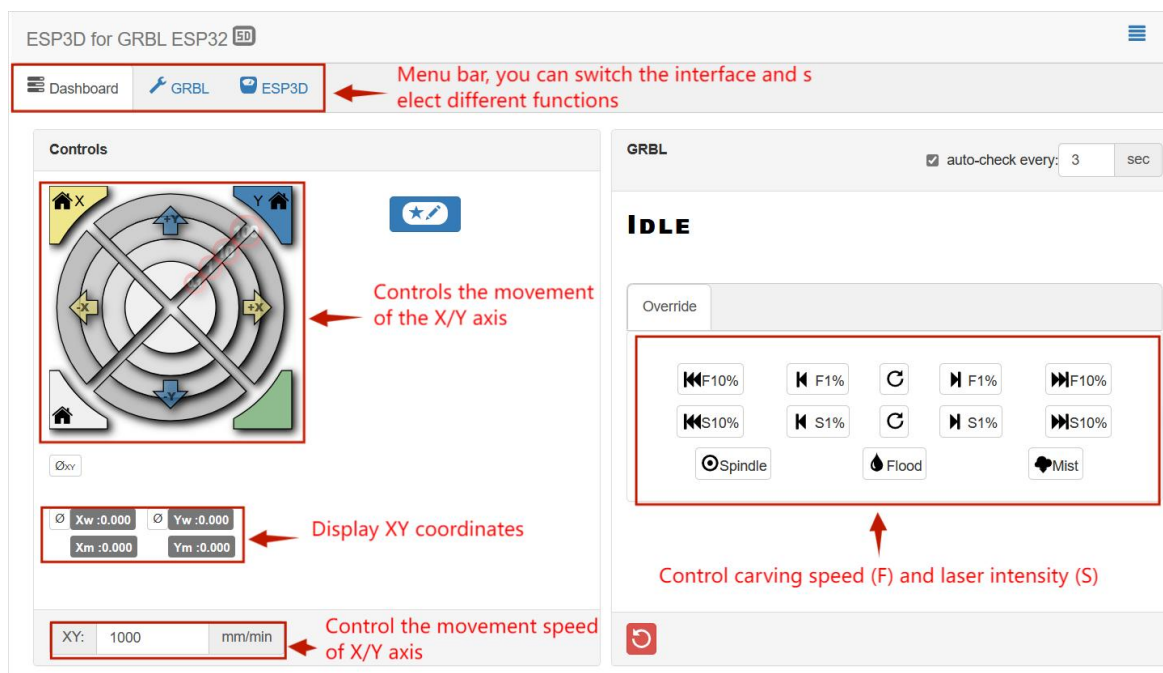

- c) Slide the mouse down to the SD file page.

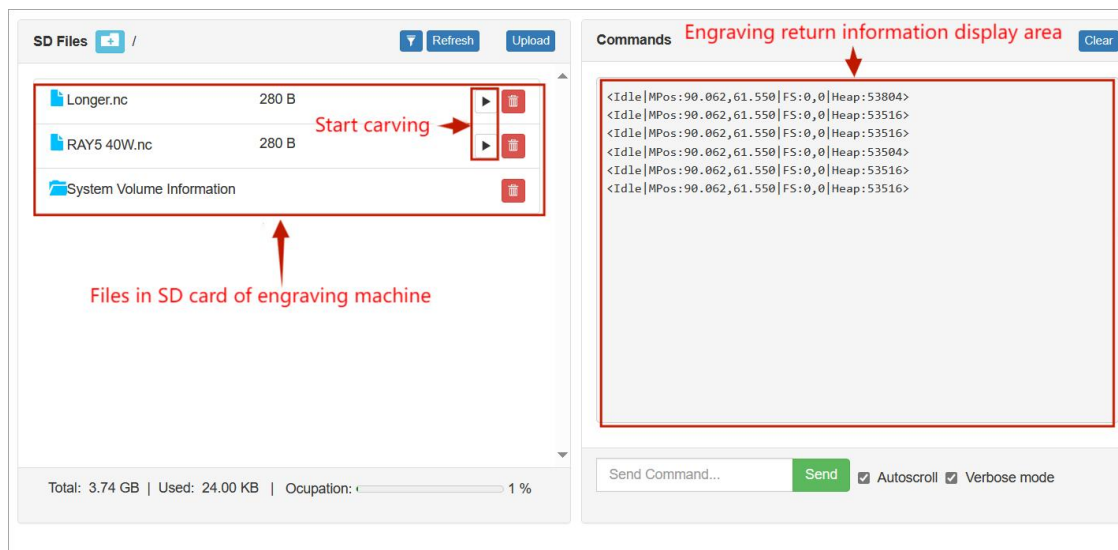

- d) Upload “.gcode/.nc” files generated by “LaserGRBL” or “LightBurn” software(The two software are introduced in the following sections). Then go and play!

(5) LaserGRBL Software Operation

LaserGRBL is an easy-to-use and fully free software for laser engraver only running on Windows.

Setup

- a) Find LaserGRBL software in attached SD card(path: /software), Or download from the link: <https://lasergrbl.com/download/>
- b) After installing laserGRBL, power up the **Ray5**, press the power switch button, and connect the laser engraver and computer via USB cable.
- c) Open LaserGRBL, select correct port(depend on your PC),

baud rate: 115200. Then click connect button.(If you cannot find correct port, please install CH340 driver manually by click Menu >> Tools >> Install CH340 Driver in LaserGRBL)

Usage

a) Main Interface

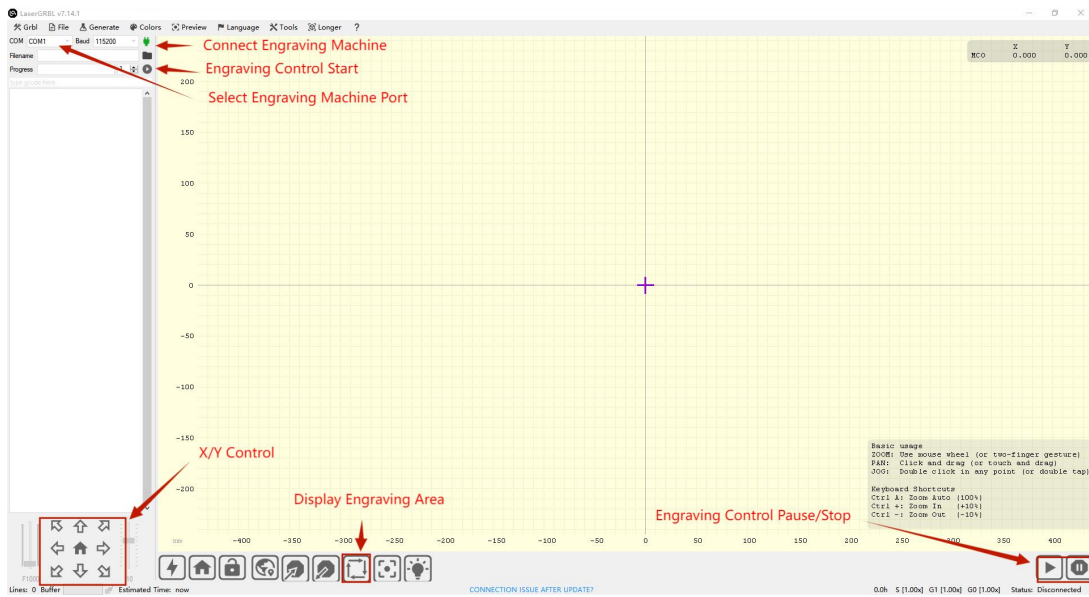

b) Open file and set parameters

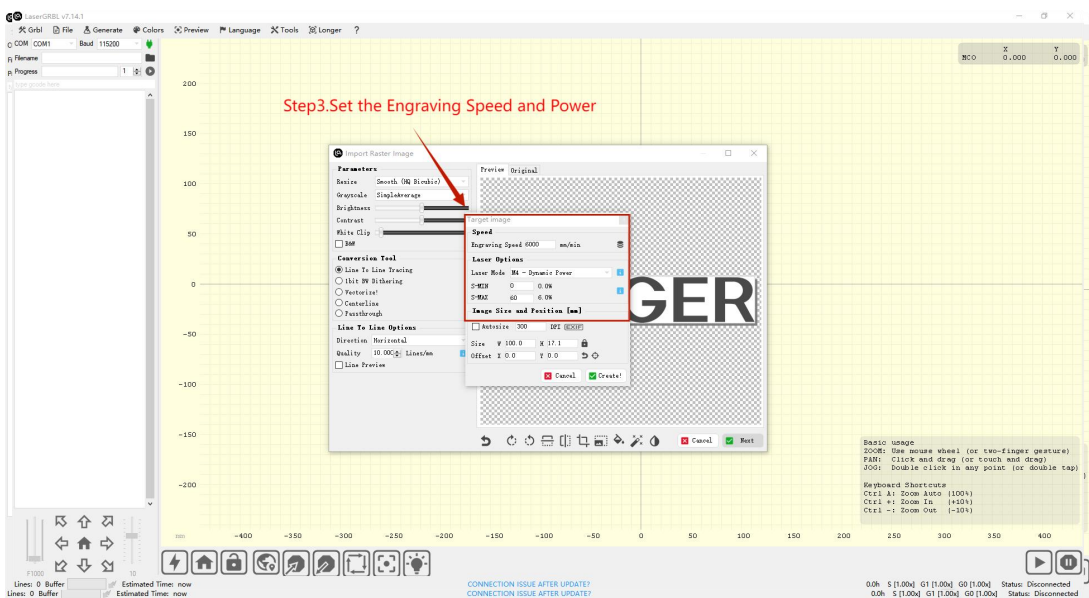

- c) Start to engrave
- i. Place a board under the laser, then calibrate the laser.
 - ii. Move the laser head to the place you want.
 - iii. Click “Frame” button to check the work frame.
 - iv. Click  button to start engraving.

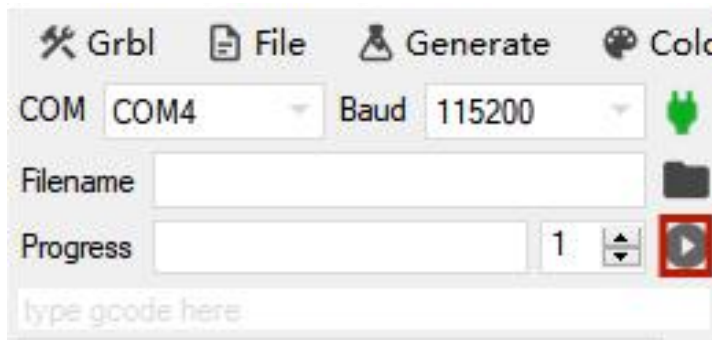

- v. Or you can save gcode file to SD card by click “File” >> “Quick Save” for offline working.

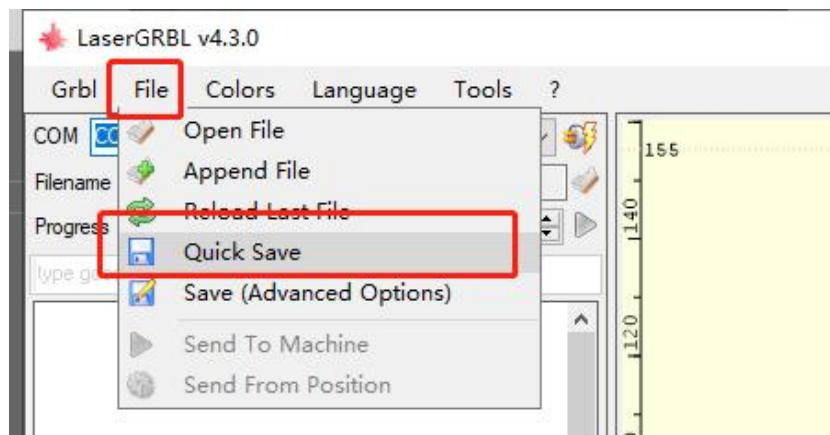

More help information about LaserGRBL, please refer to the link:

<https://lasergbrl.com/usage/>

(6) LightBurn Software Operation

LightBurn is a professional software for engraver, a charging

software running on Windows, MacOS, and Linux. It provides a trial period. You could pay for it afterward if you like it.

Setup

- a) Find Lightburn software in SD card(path: /software) came with the package. Or just download from the link:
<https://lightburnsoftware.com/download/>
- b) After installing Lightburn, power up the **Ray5**, press the Power Switch button, and connect the laser engraver and computer via USB cable.
- c) For the first time launching LightBurn, it will prompt a “New Device Wizard” for help you setup machine.
- d) Select GRBL form the list, then click “Next” button

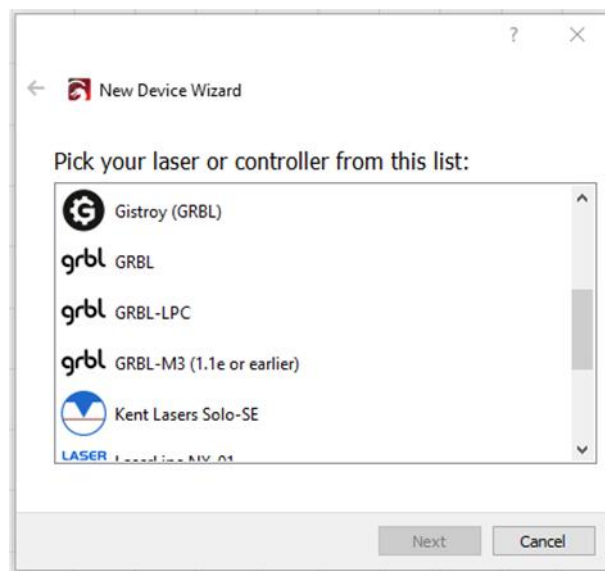

- e) Select Serial/USB and press “Next” button.

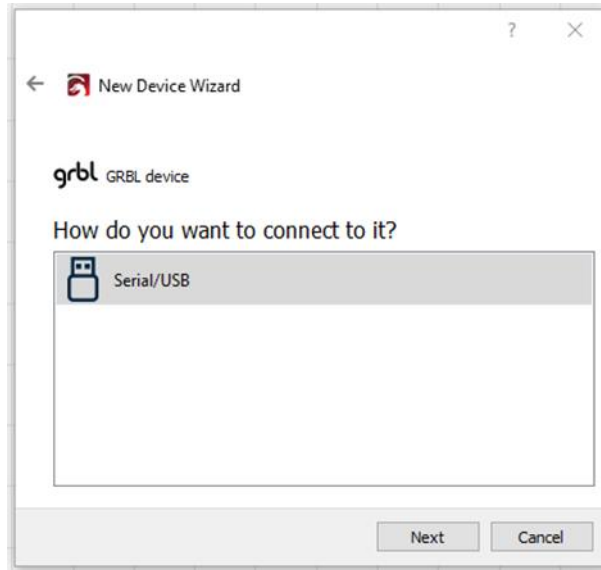

f) Fill your Device Name, X, Y axis, then click “Enter” button

Name: **Ray5 40W**

X = 385

Y = 385

The max engrave size of Ray5 40W is different from Ray5 10W or 20W, so if you own RAY 10W or 20W before, please add the new engraver manually before using the Ray5 40W.

g) Select “Front Left” as your Origin X,Y and deactivate “Auto ‘Home’”, then click “Next” button.

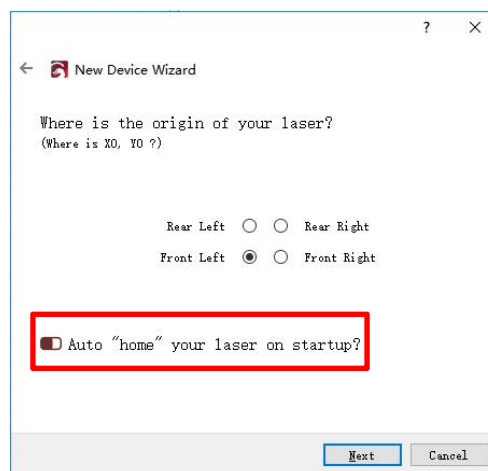

h) Select **Ray5** and press Make Default. Your **Ray5** is ready to be used in LightBurn software.

Usage

a) Main interface

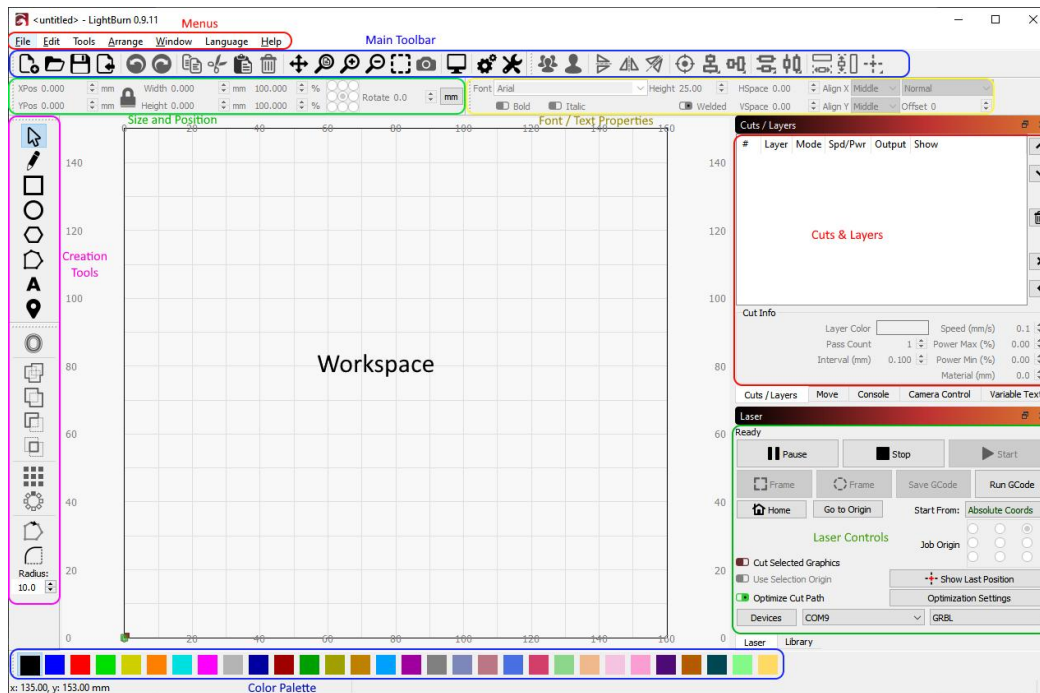

b) Select correct port (depends on your PC), then the **Ray5** is connected to the computer.

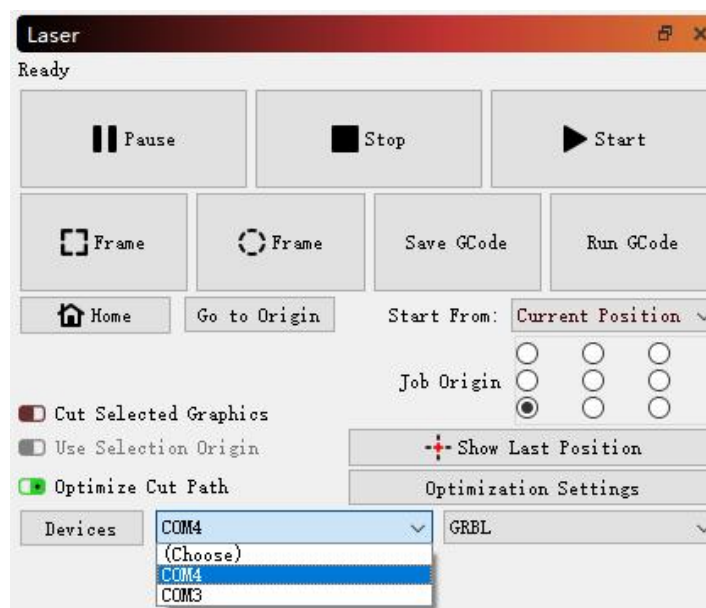

c) Click Menu “File” >> “Import image from disk.” Or just use draw tool on left column to design your own pattern.

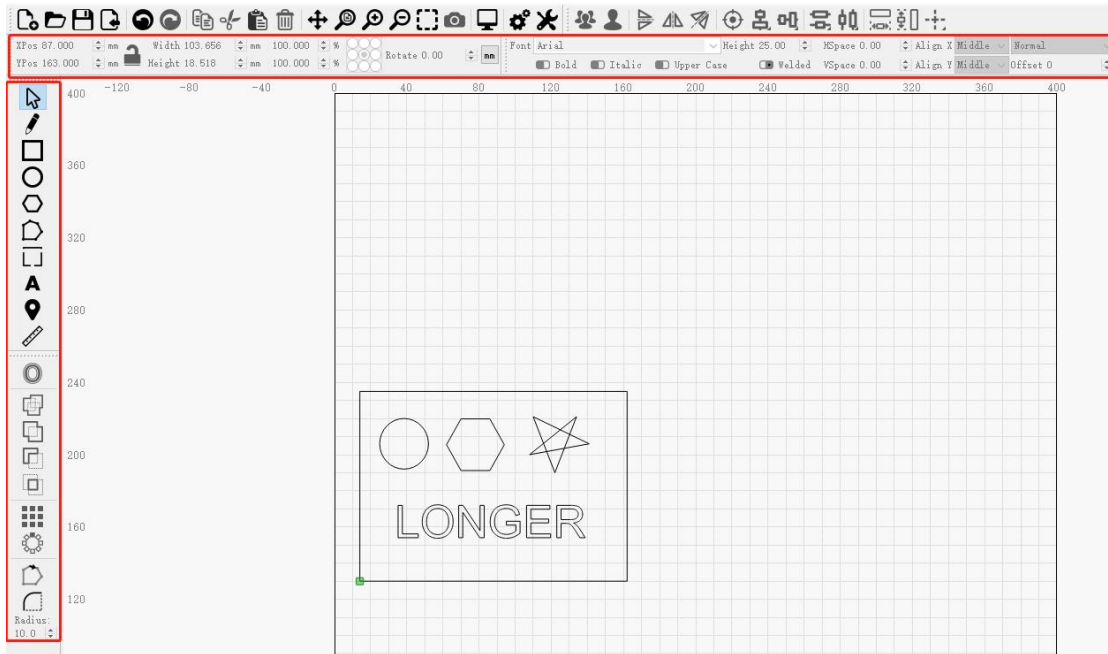

d) Set the name, speed, maximum power, mode, and other parameters in the cutting/layer; (engraving function and cutting function are only different in speed, power. Normally, the cutting speed parameter is slower).

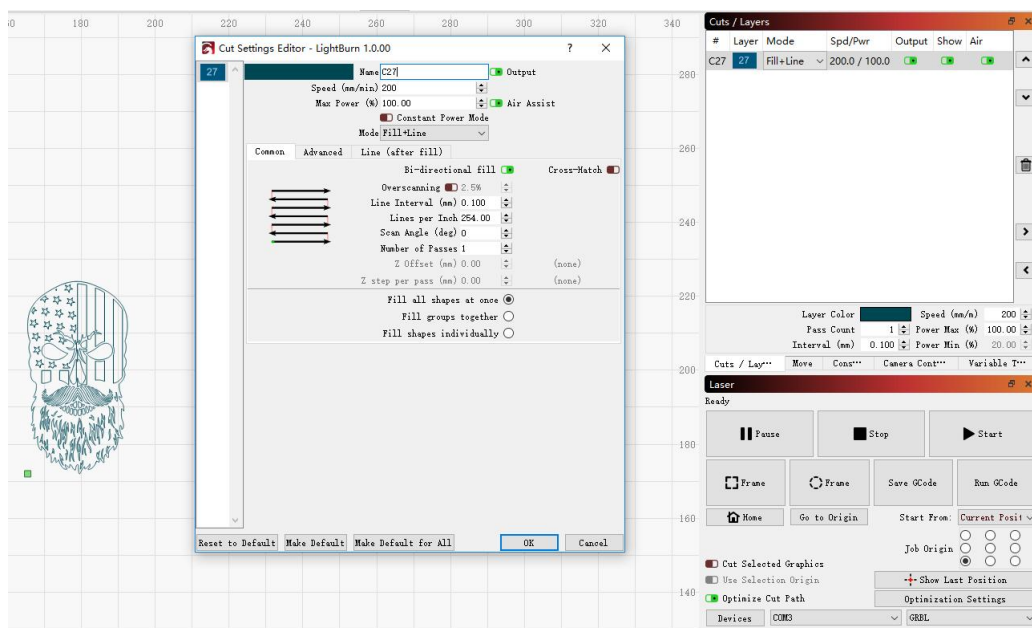

- e) After placing the board under the laser, click **Frame** to check the laser path whether is completely inside of the board.
- f) Click “Start” to start to work.
- g) Or you can save gcode file to SD card by click “Save GCode” button in Laser panel for offline working

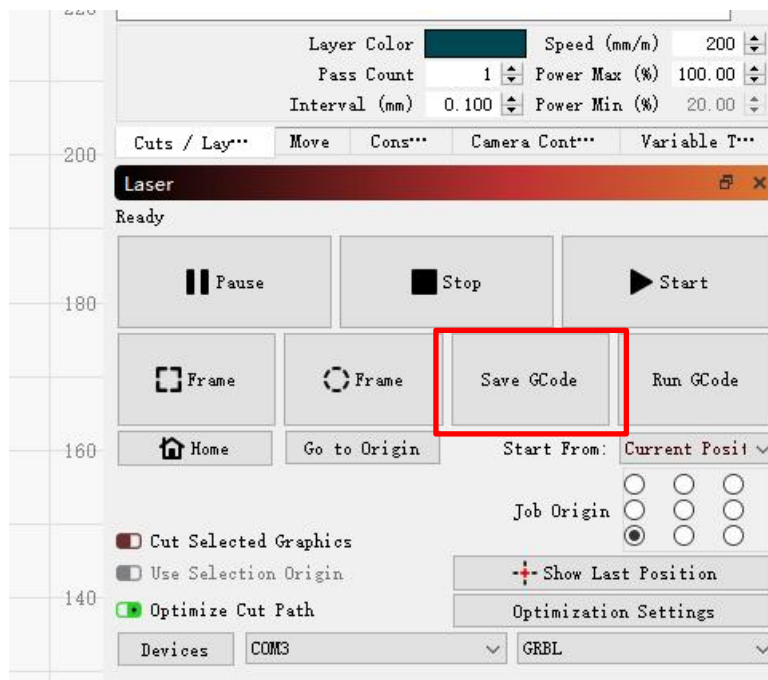

More help information about LightBurn, please refer to the link:

<https://lightburnsoftware.com/pages/tutorials>

(7) Firmware Upgrading

The Firmware of **Ray5** is continuously updated for fixing bugs and add new features. The firmware upgrade operations are different for different systems. The detailed tutorial about firmware upgrading is contained in the firmware package. Please download

Ray5 firmware package from the LONGER official website:

www.longer3d.com/pages/download

Enter <https://espressif.github.io/esptool-js/> in the browser. This webpage can connect to the serial port to flash the firmware online. Select the baud rate 115200 and connect to the CH340 serial port, then Click “Erase Flash” first, then enter the Flash address 0x0 and select the firmware, then click Program to start burning.

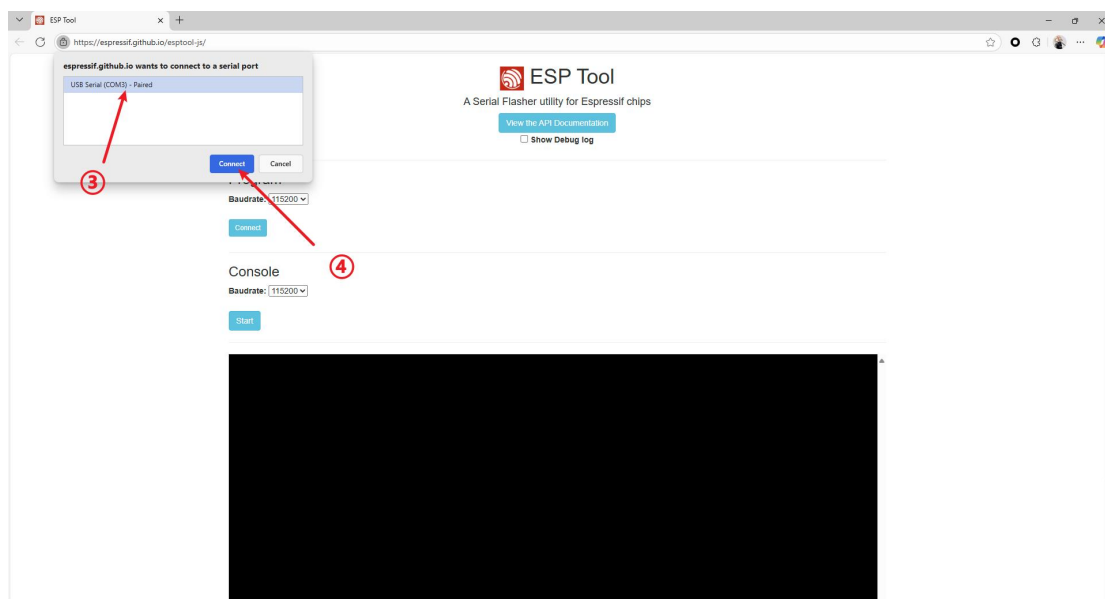
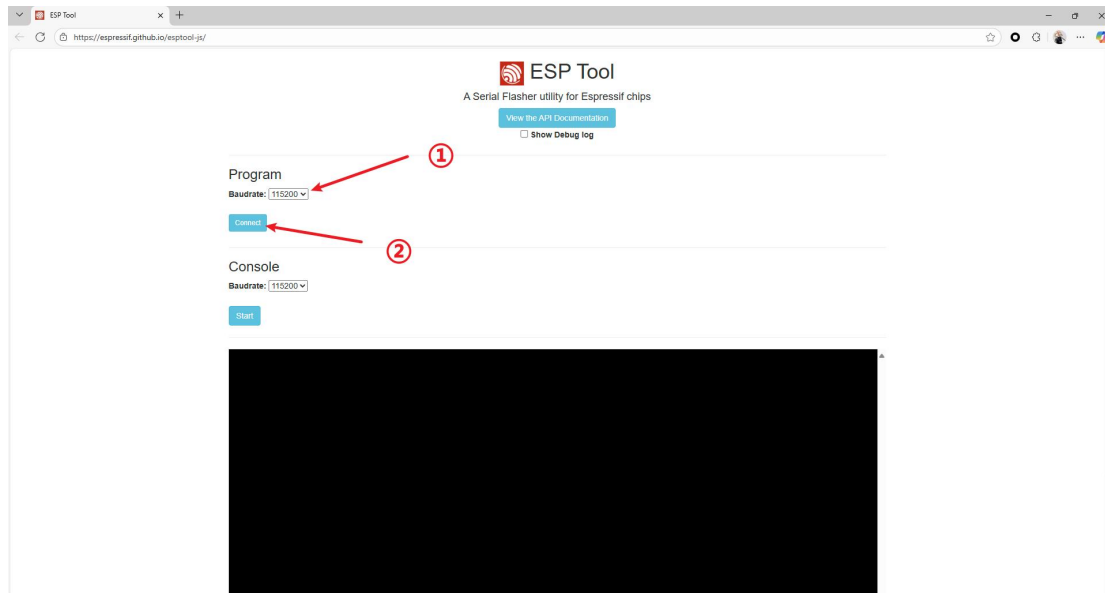

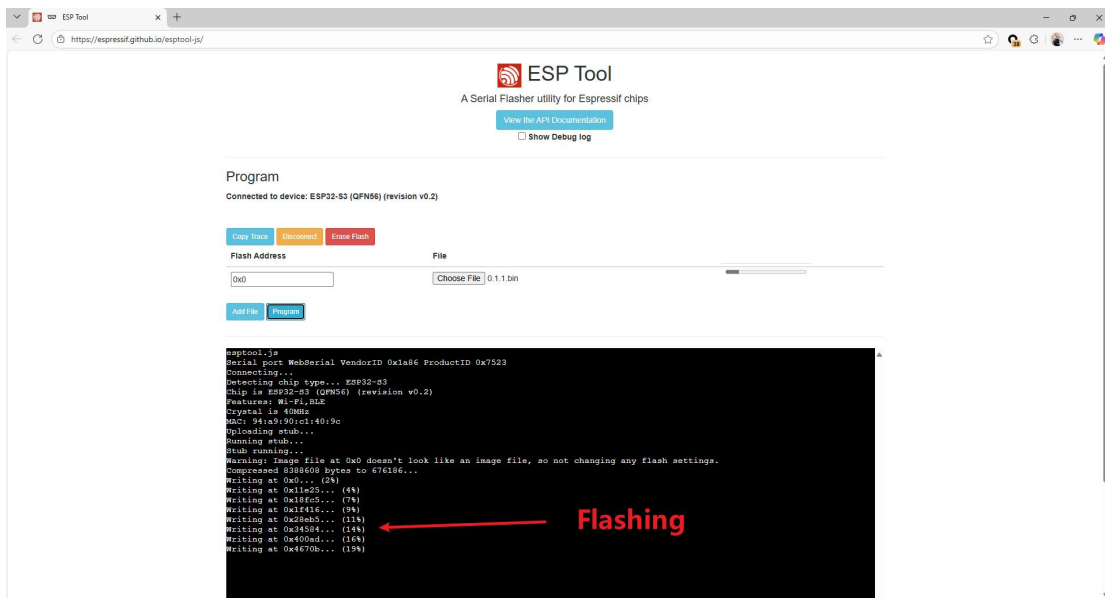
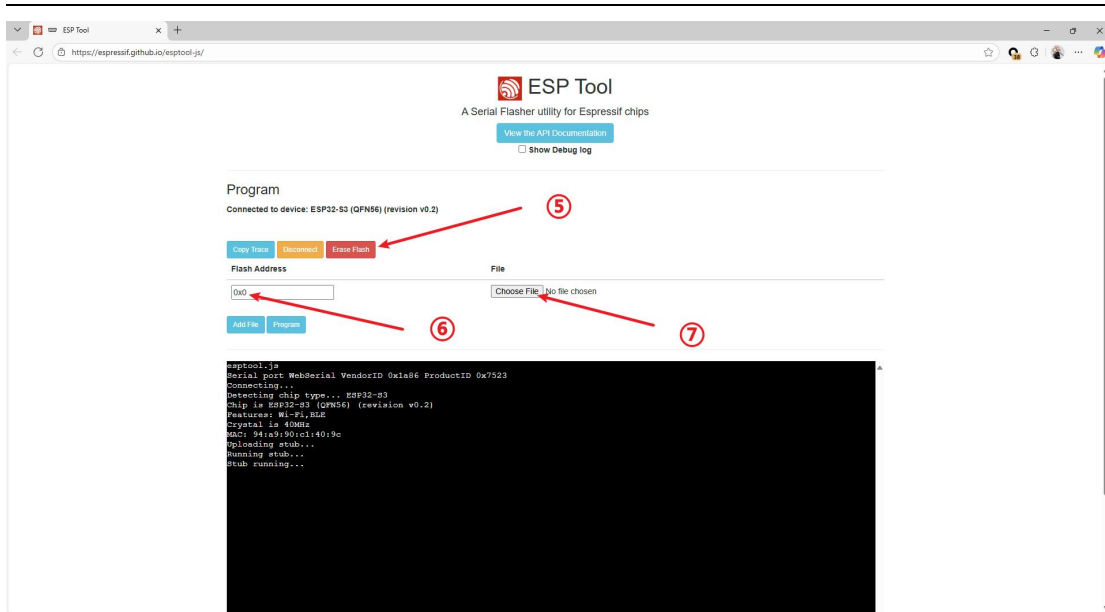

(8) APP Operation

Ray5 can be controlled or engraved through LaserBurn APP when the engraver and APP are connected to the same WIFI.

A) How to download the LaserBurn APP

Please search for "LaserBurn" in Google play or app store or visit

the address below to download Android system

https://play.google.com/store/apps/details?id=com.longer.longerlaser&hl=en_US

Please search for "LaserBurn" in the app store or visit the address below to download

<https://apps.apple.com/us/app/laserburn/id6451089363>

Or download from LONGER's official website:

<https://www.longer3d.com/pages/longer-app>

Or scan the code to download the APP:



For complex grayscale engraving, it is recommended to transfer the image to the mobile phone album and import it into the APP for engraving, which will have a better effect.

B) Connect to WIFI in AP mode

Note: There are two modes, AP and STA, to connect Ray5 via WIFI.

The difference is that in **AP mode the phone will have no network, but in STA mode the phone can maintain network.**

1. Run the LaserBurn APP and enter the Home page, click not

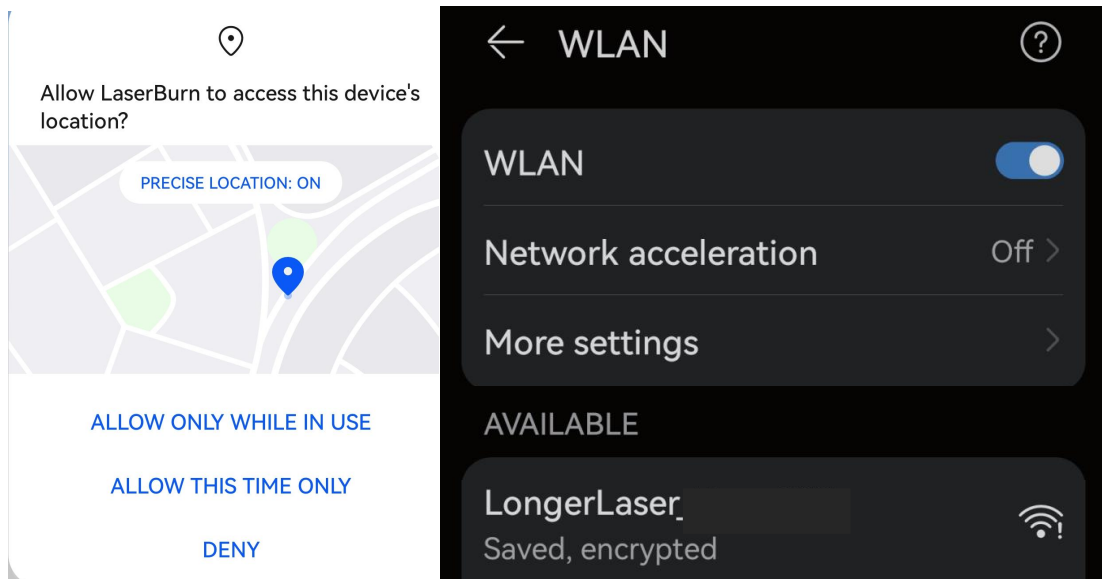

connected icon.  when there is a 'Allow LaserBurn to access this device prompt, you need to click 'Allow only while in use', otherwise you may not be able to search for WIFI of Ray5.

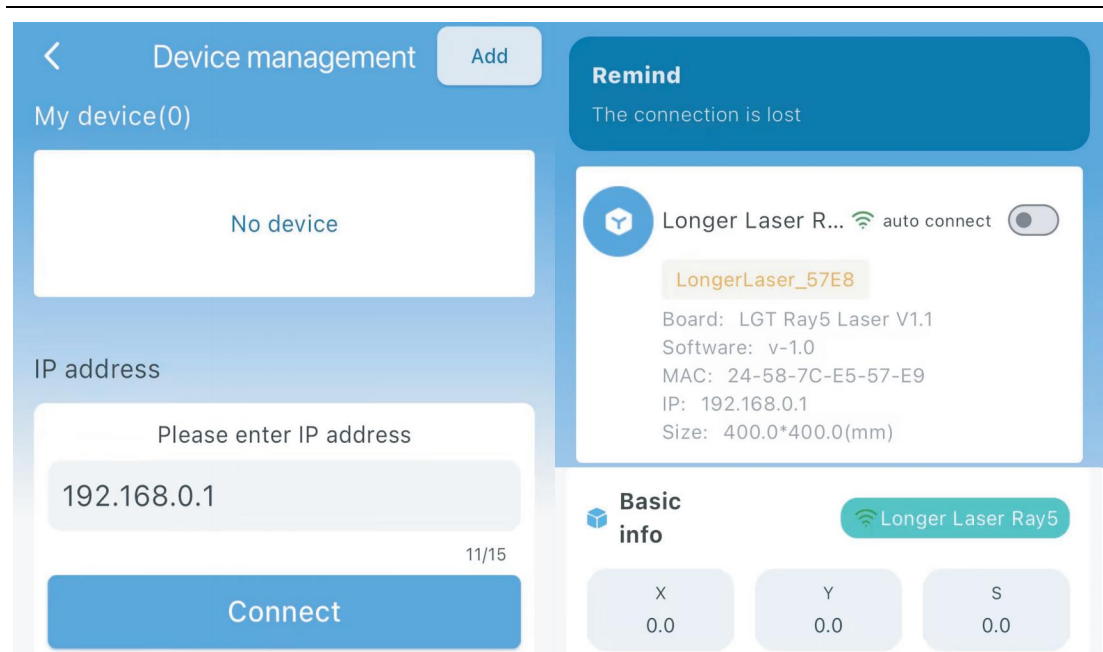

2. Open the [WLAN](#) settings on your phone, search for the WIFI starting with [LongerLaser](#) and input [password 12345678](#) to connect the wifi of Ray5.
3. Enter the IP address [192.168.0.1](#) below, click [Connect](#). There will be a remind 'connection succeeded' when connect successful



C) Connect to WIFI in STA mode

1. Open the **WLAN** settings on your phone. Run LaserBurn and enter the Home page, click **not connected icon**  enter the network configuration page , click **Add**  in the upper right corner.

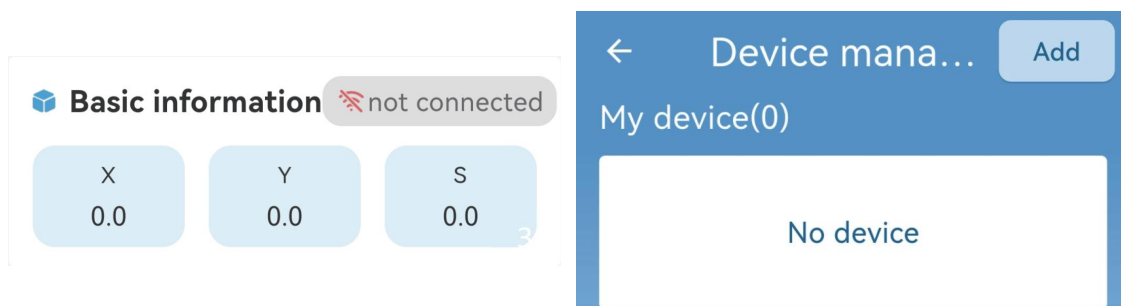

2. Click Scan Device, search and find the WIFI that starts with **LongerLaser_**, click it, jump to the mobile phone WIFI list, enter the **password 12345678**, and connect to Nano Duo's WIFI.

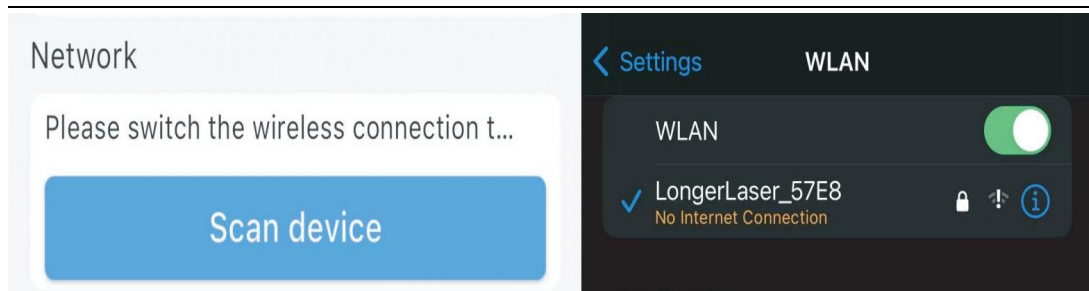

3. After the connection is successful, return to LaserBurn, select **Set STA mode** to connect WIFI of router (only **supports 2.4G**), and enter the password.

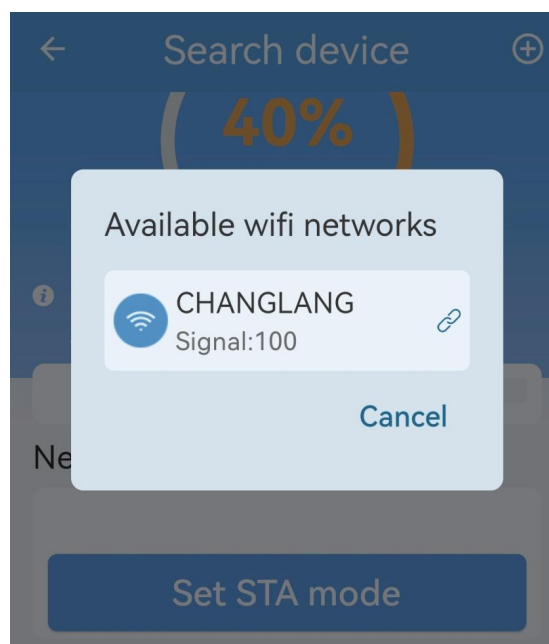

4. Back to LaserBurn, click **Connect network** at the bottom of the page, connect the phone to the same WIFI as the STA mode in the previous step, wait for network configuration. When the connection is successful and the network process reaches 100%, click **FINISH** at the bottom to return to the device list interface.

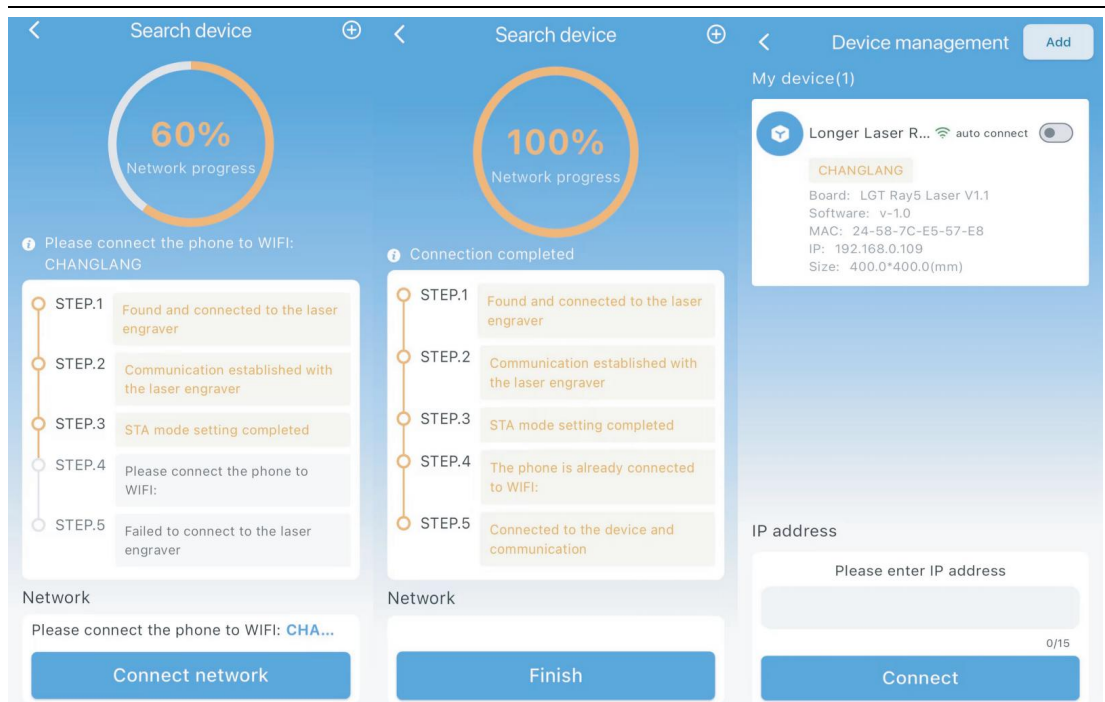

Note: After the device is connected, when click anywhere on the device list label, the machine will disconnect; conversely, if click when the device is disconnected, the phone will automatically connect to the device.

D) Creation

1. In the creation interface, graphics can be imported through painting, text, QR code, photo album, camera, material library, AI generation, etc.

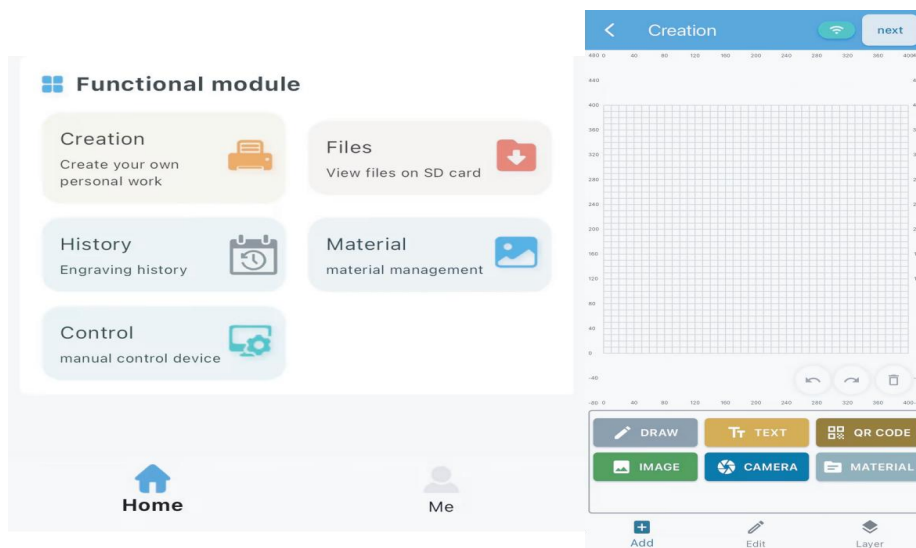

2. Draw

Draw simple images, such as circles, rectangles, triangles, etc.

The screenshot displays the LONGER software interface. At the top, there is a blue header with navigation arrows, the word "Creation", a Wi-Fi icon, and a "next" button. Below the header is a grid with axes ranging from 0 to 110. A toolbar contains icons for drawing a line, a diagonal line, a circle, a square, and a triangle. The square icon is highlighted in blue.



Two side-by-side grid views illustrate the drawing process. The left grid shows a yellow square with a width of 25.0 and a height of 50.0, positioned at X=30.0 and Y=25.0. The right grid shows the same square rotated 45 degrees, with its bounding box dimensions and position updated to W: 25.0, H: 50.0, X: 15.98, and Y: 23.48.



Below each grid is a control panel for the selected square. The left panel shows:

- Layer:00 Speed:6000 Power:10.0
- Size W: 25.0 H: 50.0
- Position X: 30.0 Y: 25.0
- Rotate 0°
- Buttons: Add, Edit, Layer

 The right panel shows:

- Layer:00 Speed:6000 Power:10.0
- Size W: 25.0 H: 50.0
- Position X: 15.98 Y: 23.48
- Rotate 45°
- Buttons: Add, Edit, Layer

Enter the value in **Size** to scale the graphic proportionally or hold down the button  to drag. If you need to change the length and width of the graphic separately, you can click the button  to unlock the

proportional lock; enter a value in **Position** to change the position of the graphic, or select the graphic and move it within the canvas by dragging it; enter a value in **Rotate** can rotate the graphic counterclockwise to the corresponding angle, or hold down the button  to rotate the graphic at any angle; if you click the button , the size, position or angle of graphic can only be changed by entering a value; click the button  can delete graphics.

3. Text

Enter text and change the font, text size, position and angle.

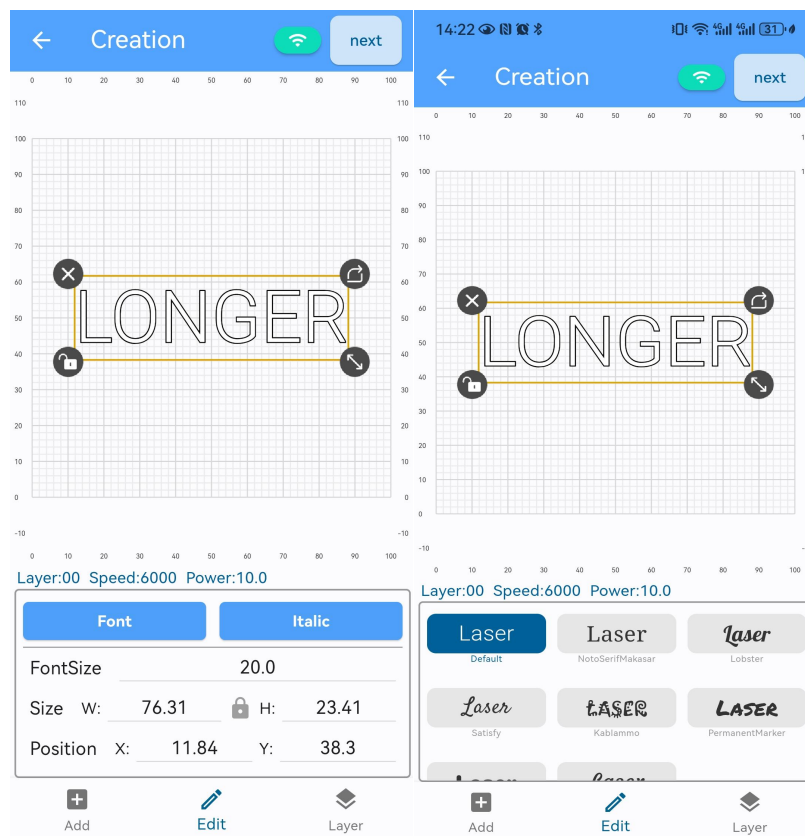

4. QR code

Generate QR code based on the input content, and change the size, position or angle of the QR code.

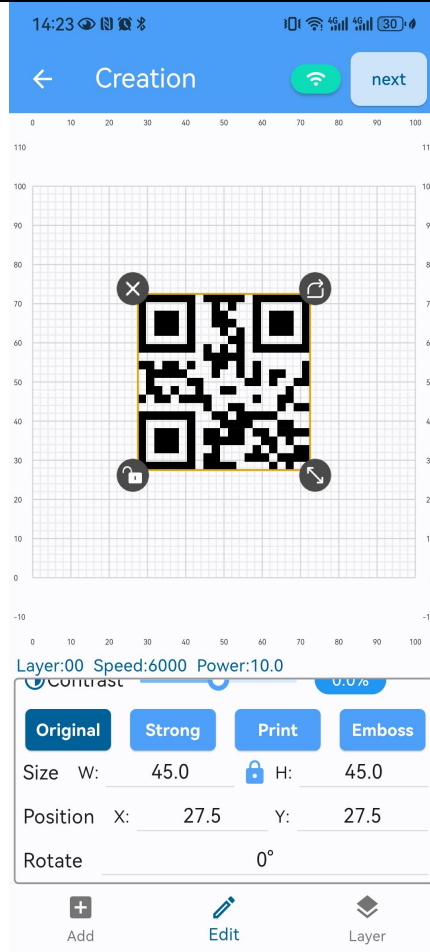

5. Layer

Layer mode: set line or fill

Laser type: choose 5W for Ray5,10W for Ray5,20W for Ray5, 30W for Ray5,40W

Processing method: engrave or cut

Material: select the corresponding material from the material

library , and the APP will automatically set the appropriate

parameters according to the processing method and laser power

selection. If the parameters need to be modified, click the edit

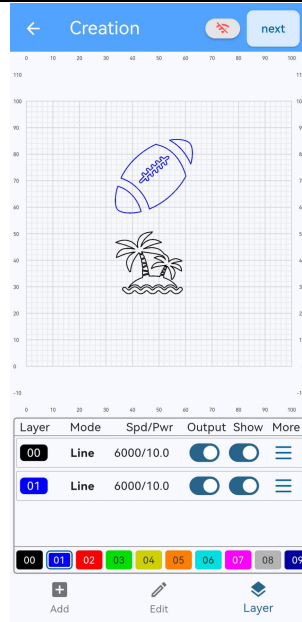

01 Line



Mode Line Fill

Laser type 5W 450nm Blue light

Processing method Engrave Cut

Material Basswood

Laser power 100.0%

Speed 3000 mm/min

Times 1

Accuracy 0.06 mm

Material

- Nothing
- Basswood
- Solid wood
- Alumina(black)
- Leather
- Denim

00 Line



Mode Line Fill

Laser type 5W 450nm Blue light

Processing method Engrave Cut

Material Basswood (2.0mm)

Laser power 100.0%

Speed 300 mm/min

Times 1

Material

- Nothing
- Basswood (thickness:2.0mm)
- Basswood (thickness:4.0mm)
- Paulownia wood (thickness:6.0mm)
- Iridescent paper (thickness:0.1mm)

6. Album

Import pictures from the mobile phone album.

7. Camera

Use the phone camera to shoot pictures and import to APP.

8. Undo



Undo the last operation, up to 20 steps can be supported.

9. Redo



Redo the last operation, up to 20 steps can be supported.

10. Clear



Clear all graphics in the canvas.

11. Copy



Copy the original material

12. Flip Horizontal



Image is upside down

13. Flip Vertically



Mirror image left and right

E) Files List

After connecting to the engraving machine, you can preview the file data uploaded to Nano Duo. Select a file from the list and swipe left or tap the upper right corner to delete it. **When the reserved memory is about to run out, please clean up unnecessary files in time, otherwise you will not be able to upload new files.**

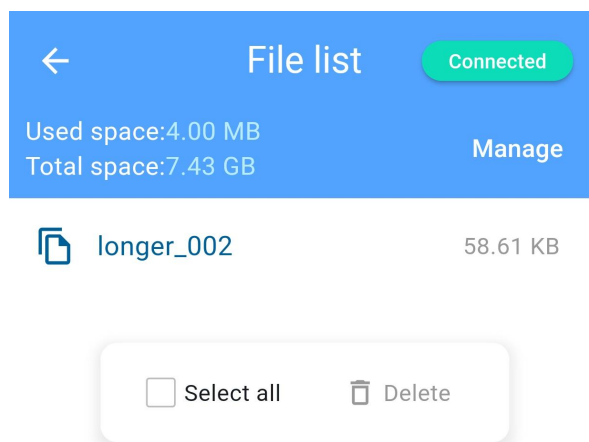

F) History

History displays a graphic history list of operations on the APP. You can long press a file in the list to delete unwanted images.

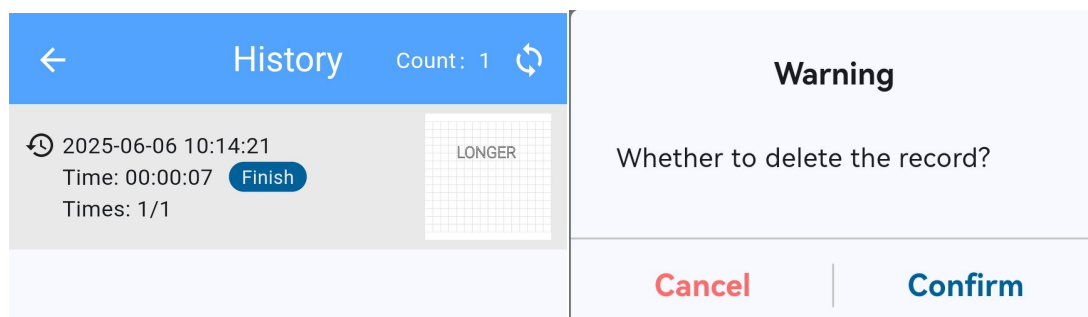

G) Material

Material: Graphic library in the APP. Click the **ADD** button in the upper

right corner can add graphics from the phone album or phone memory. Long press on the self imported image can delete it, but the built-in image cannot be deleted.

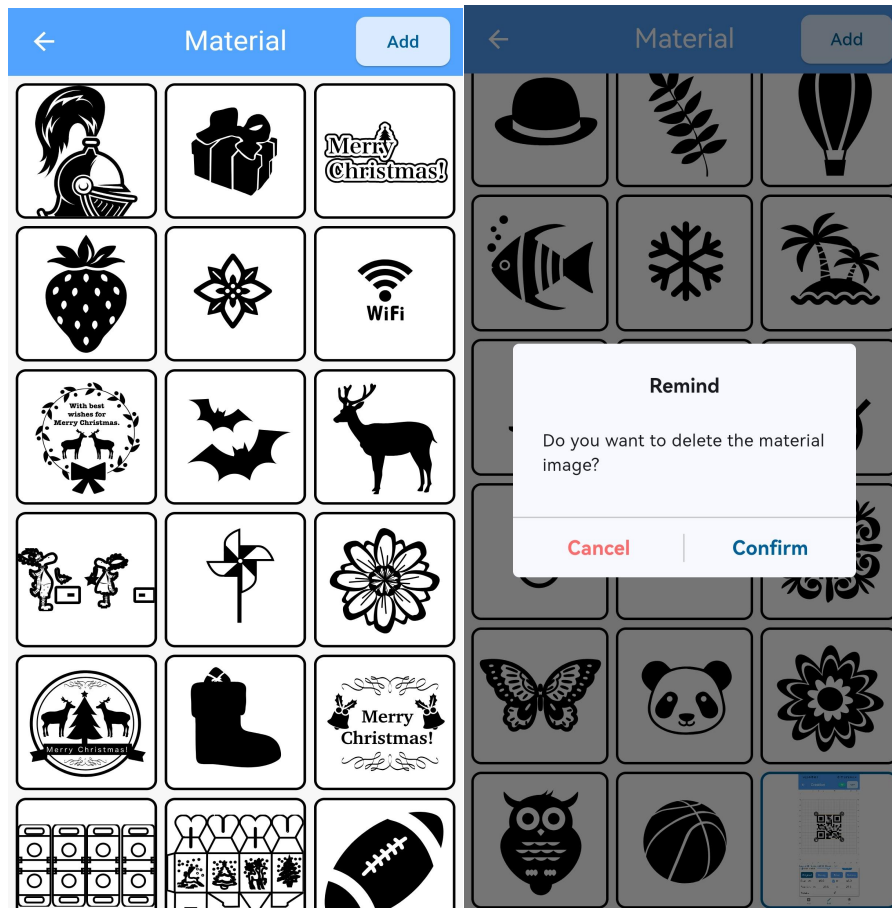

H) How to make a project on LaserBurn APP

1) Run LaserBurn app and connect the APP to Nano Duo, add a graphic, click [Edit](#) to set size and position, click [Layer](#) to set the parameter of the graphic, then click [next](#) in the upper right corner.

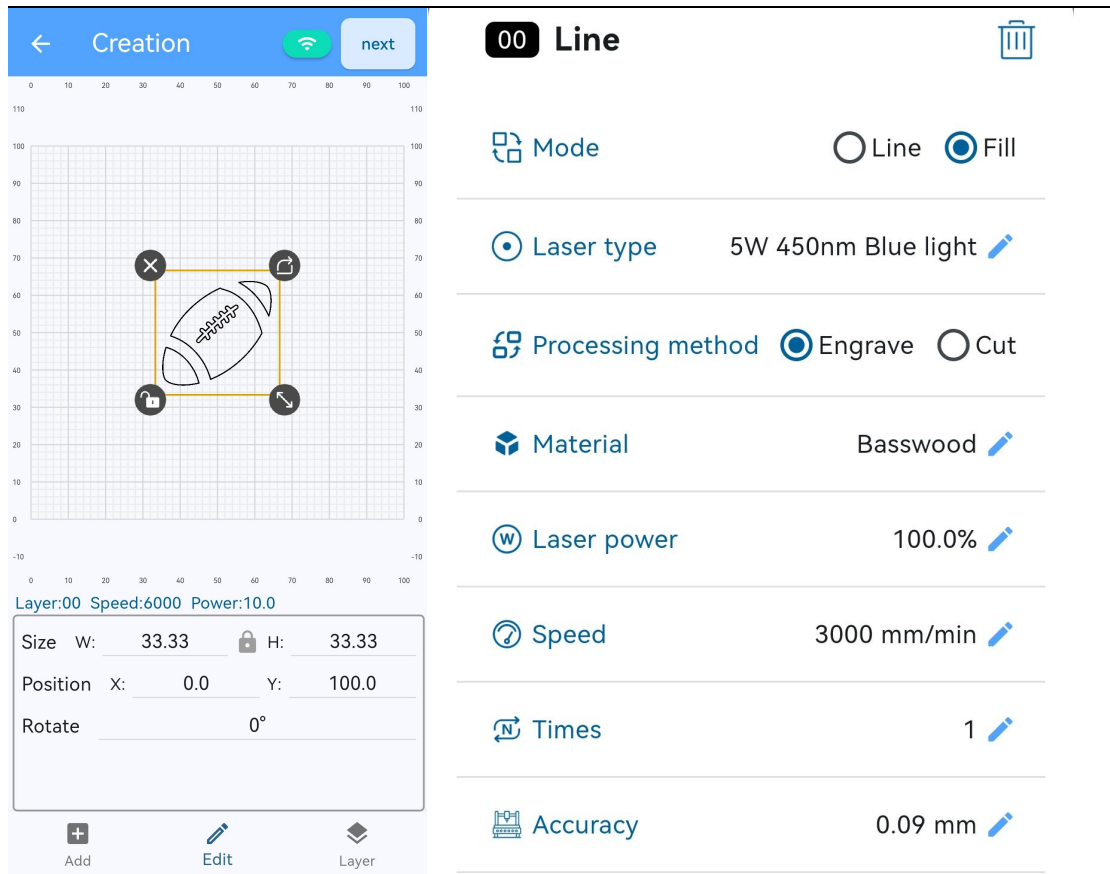

2) There will be a warning window, make sure the work area is safe, wear goggles and protective cover is installed, click Confirm.

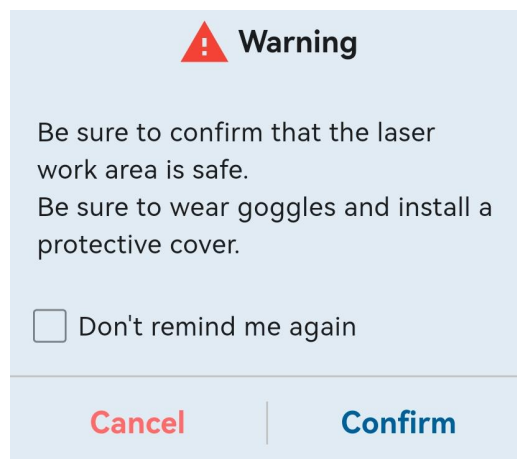

3) Click the Border settings, enter border settings Can modify speed and laser power

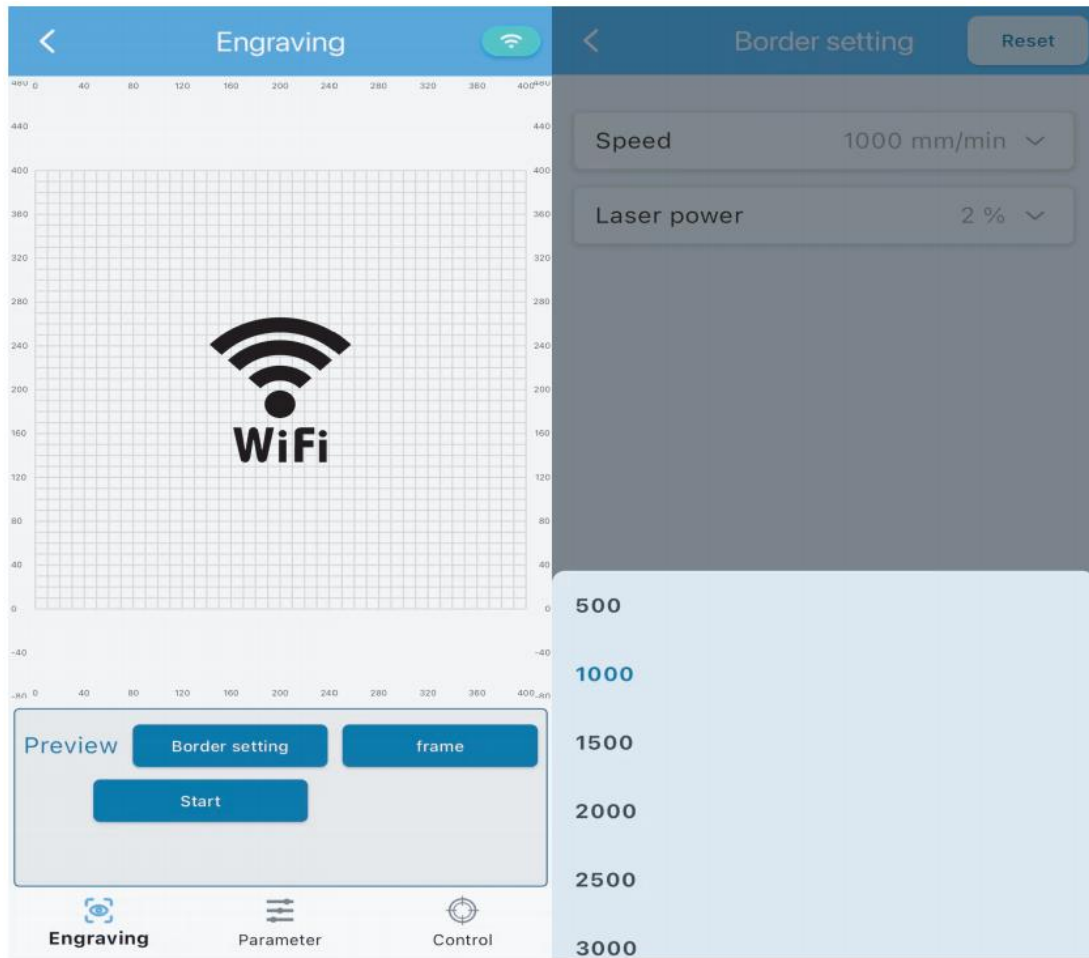

4) Click ed frame Button,Patrol frame



5) After confirming that the focus is adjusted normally and the goggles are worn, click Confirm to make sure the file name, and then the file starts to upload to the Ray5. After the upload is completed, The machine starts running

<p> Warning</p> <p>Please check the focal length.</p> <p><input type="checkbox"/> Don't remind me again</p>	<p>Input file name</p> <p>longer_002</p>
<p>Cancel Confirm</p>	<p>Cancel Confirm</p>

6) The APP will display the task progress. You can click **Pause** to pause the task, or click **Start** to start the task. When the task is completed, there will be a 'Work completed' prompt. Click confirm to return to the Home page.

<p>Remind</p> <p>Please press the [▶] button on the machine to start carving</p>
<p>Confirm</p>

D.FAQ

Question 1: Are there recommended engraving and cutting parameters?

Please refer to the table “LONGER Laser Engraver Material Profiles” which describes the common materials engraving and cutting parameters for Ray5 40W.

If there is no information you need. Please wait for our updates in the future.

Question 2: The engraved pattern appears vibration, or is not closed?

- Adjust the eccentric nut to make the parts move smoothly without shaking.
- Re-tension the timing belt.
- Adjust the synchronous wheel to prevent the synchronous belt from rubbing against the side of the synchronous wheel during movement.

Question 3: How about the warranty policy?

For LONGER official stores and LONGER designated distributors, Ray5 40W has a One-year International Limited Manufacturer warranty from the date of purchase of Ray5 40W.

Please note the following warranty terms. One-year International Limited Manufacturer Warranty means that LONGER will provide the following free warranty services:

- Diagnostics and Evaluation.
- Technical Support.
- Replacement Parts under Warranty terms.

How to handle a warranty case:

Any warranty case must be submitted to our official support channels (Email: support@longer3d.cn). In case the product was bought from a reseller, contact us first so that we can help you diagnose the problem, then turn to your reseller for spare parts if needed.

Documentation needed for a warranty case:

1. Machine purchase order number and channel, nameplate number on the machine.
2. A brief description of the problem along with the clear evidence of its presence (e.g., photos or videos).
3. On the initial contact for customer support further tests and diagnostic steps might be required to identify the cause of the

problem.

4. Some parts of the Ray5 40W inevitably “get used up” over time.

For these parts, specific conditions apply, unless failure has occurred due to a defect in materials or workmanship.

Part	Warranty Limitation
Motherboard	One-year International Limited Manufacturer Warranty
Motor	One-year International Limited Manufacturer Warranty
Longer Laser Module	One-year International Limited Manufacturer Warranty
Touch Screen	One-year International Limited Manufacturer Warranty
Power Adapter	One-year International Limited Manufacturer Warranty
Chrome-Plated Rod	Warranty does not apply on normal wear and tear
2020 Profile	Warranty does not apply on normal wear and tear
Coupling	Warranty does not apply on normal wear and tear
Eccentric Nut	Warranty does not apply on normal wear and tear
Bearing	Warranty does not apply on normal wear and tear
L-Shaped Right-Angle Foot Slot	Warranty does not apply on normal wear and tear
Goggles	Warranty does not apply on normal wear and tear
Brush	Warranty does not apply on normal wear and tear
Board\ Acrylic Board\ Stainless Steel Plate	Warranty does not apply on normal wear and tear
Linear Bearing Wheels	Warranty does not apply on normal wear and tear
GT2 Timing Belts	Warranty does not apply on normal wear and tear
Powder-Coated Aluminum Extrusion	Warranty does not apply on normal wear and tear
Cables & Drag Chain	Warranty does not apply on normal wear and tear
Cosmetic Appearance & Logos	Warranty does not apply on normal wear and tear

Note:

- The warranty does not cover normal, expected wear and tear caused by using the Ray5 40W for its intended purpose.
- In case we have provided a free replacement part, the warranty does not reset. The original warranty period still applies.

This warranty is voided by:

- Any damages caused by improper assembly of the product.
- Any damage caused by improper use, maintenance, or operation of the engraver.
- Any damage caused by long-term lack of maintenance.
- Using the Ray5 40W in improper conditions (temperature, dustiness...).
- Upgrades, modifications, or add-ons that are not officially supported.

Our Technical Support Team is always available to help you out under any circumstances, even if the issue is not covered under warranty.

Question 4: How to maintain Ray5 laser module?

Ray5 40W's lasers are carefully designed to resist stains, but after long-term use, there may still be dust and grease on the laser hood, air guide, and even the lens. This will affect the appearance and performance. It is recommended to clean the laser regularly to keep it in good performance. You need to perform the following steps to clean the laser.

Preparation: hex wrench, non-woven fabric, alcohol/isopropanol solution.

Start:

1. Remove the laser hood and air guide
2. Dip a little alcohol/isopropyl alcohol solution with a non-woven fabric
3. Carefully wipe the laser lens with a non-woven fabric
4. Reinstall the laser hood and air guide

Warning: Excess solution may immerse inside the laser and cause damage to the laser.

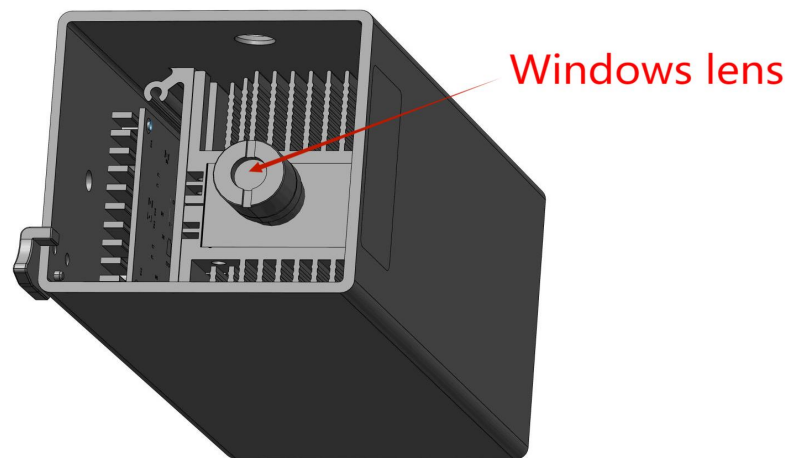

Ray5 40W laser module

Question 5: How to solve alarm 2 error or hard limit?

ALARM:2

G-code motion target exceeds machine travel. Machine position safely retained. Alarm may be unlocked. (Right-click the 'Devices' button to reset the connection)

On or near line 2:

It adds two limit switch in Ray5 40W laser engraver, the firmware has hard limit and soft limit features to locate the laser module position precisely. The position of the laser module is assumed to be the home position by default when powered on. So the engraver will trigger the alarm 2 or hard limit error if the laser head is moved in the X or Y negative direction at this time. Then it needs to home the engraver as shown in the picture below.

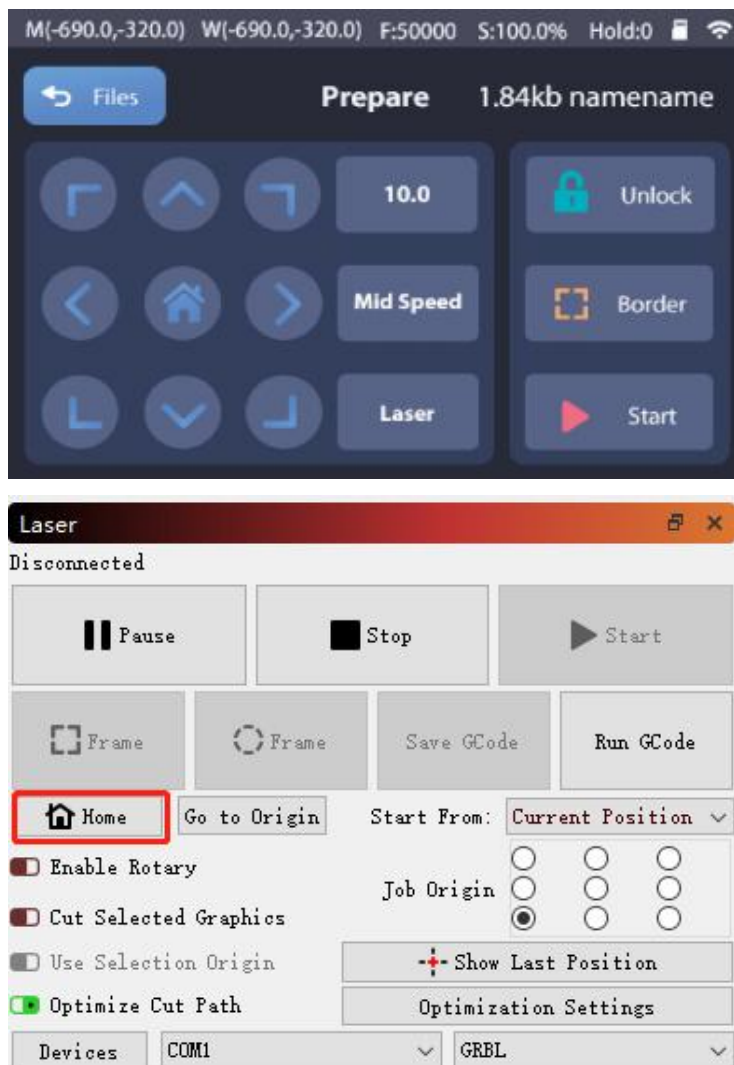

Question 6: How to solve the upload error of the APP?

To use APP for engraving, it needs to insert the SD card into the motherboard firstly to ensure that the data can be received normally; otherwise it will prompt upload error.