



CE FC RoHS

Quick Start Guide



www.longer3d.com



RAY5 Unboxing Video

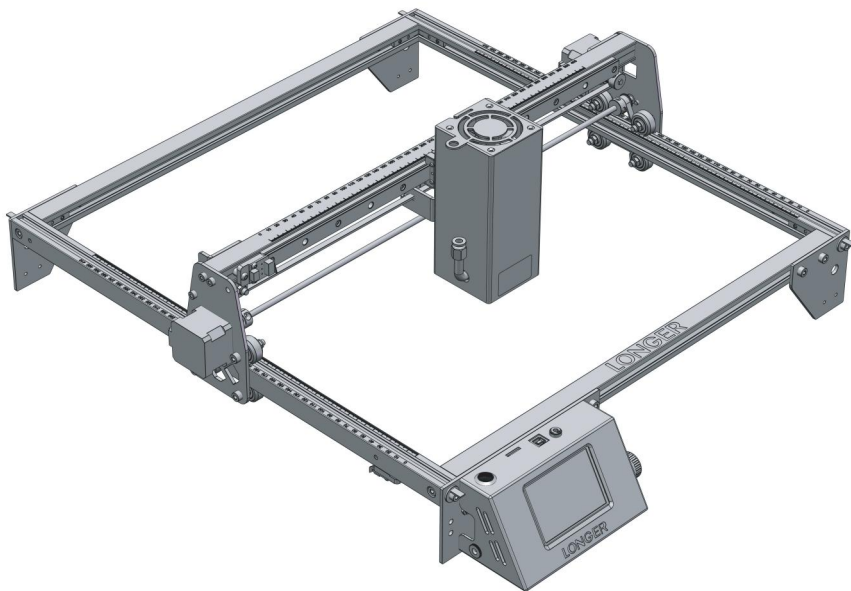

LONGER LASER ENGRAVER Ray5 40W

LaserBurn APP & Software

After-Sales Service

a) Please scan the QR code below or search for "LaserBurn" in the Google Play Store or Apple App Store to download the app.

Note: After downloading and installing the app, please carefully read the warnings and precautions in the app to ensure safe and proper use of this product.



b) Download the PC software from the link below. LightBurn is compatible with Windows and macOS systems, and LaserGRBL is compatible with Windows.

LightBurn

<https://LightBurnsoftware.com/pages/download-trial>

LaserGRBL

<https://lasergbrl.com/download/>

Please download the software, configuration file, parameter table, manual, etc. from the following links: <https://www.longer3d.com/pages/download>

Technical service for this product is available globally. Please contact us if you encounter any issues, and we will get back to you as soon as possible.

Shenzhen Longer Technology CO., Ltd.

Add: FL 10, Building 2B, Intelligent Park, 76

BaoHe Ave, Longgang, Shenzhen, China

Service Hotline: (+1)888-575-9099

Mon-Fri: 9:00am-6:00pm (EST, UTC-5)

Sun-Thu: 8:30pm-7:00am (EST, UTC-5)

Email: support@longer.net

Facebook ID: Longer Global

Facebook Group: Longer Laser Engraver Official Group

Youtube Channel: Longer Official



TABLE OF CONTENTS

! ATTENTION !	1
Laser Engraver Introduction	4
Packing List	5
Installation Steps	7
LaserGRBL Software Operation	15
LightBurn Software Operation	19
LaserBurn APP Operation	23
Warranty	32
Copyright Statement	33

! ATTENTION !

1. The Ray5 engraves and cuts materials by the means of a high-energy diode laser beam.

The hazards associated with a high-energy diode laser beam include the possibility of fires, generation of hazardous and/or irritating toxic fumes, but more importantly damage to eyes and skin.

2.  Laser engravers are divided into several internationally valid classes based on their performance and the risk of injury. The Ray5 40W falls into the Class IV (Class 4 IEC standard focus on the American FDA classification).

Laser class	Class Definition
Class I	Class I levels of laser radiation are not considered to be hazardous.
Class IIa	Class IIa levels of laser radiation are not considered to be hazardous if viewed for any period of time less than or equal to 1×10^3 seconds but are considered to be a chronic viewing hazard for any period of time greater than 1×10^3 seconds.
Class II	Class II levels of laser radiation are considered to be a chronic viewing hazard.
Class IIIa	Class IIIa levels of laser radiation are considered to be, depending upon the irradiance, either an acute intrabeam viewing hazard or chronic viewing hazard, and an acute viewing hazard if viewed directly with optical instruments.
Class IIIb	Class IIIb levels of laser radiation are considered to be an acute hazard to the skin and eyes from direct radiation.
Class IV	Class IV levels of laser radiation are considered to be an acute hazard to the skin and eyes from direct and scattered radiation. hazard to the skin and eyes from direct and scattered radiation. and eyes from both direct and scattered radiation.

The high energy laser beam can cause severe eye damage, including blindness and serious skin burns.

Improper use of the controls and modification of the safety features may cause serious eye injury and burns.



Please wear Personal Protective Equipment (PPE). Safety glasses are designed to filter specific ranges of laser wavelengths. The Ray5 40W comes with safety glasses specifically designed for the LONGER Laser Module.

DO NOT look directly into the laser beam;

DO NOT aim the laser beam at reflective surfaces;

DO NOT operate the laser without PPE for all individuals in the vicinity of the Ray5 40W;

DO NOT allow unsupervised access to the Ray5 40W by children;

DO NOT allow pets near the Ray5 40W;

DO NOT modify or disable any safety features of the laser system;

DO NOT touch the high-energy laser beam.

3. We strongly recommend placing the machine in a well-ventilated room, and at the same time, the door of the room has a sealing effect and the windows have curtains, so as to effectively avoid looking directly at the laser beam and some smoke and steam , Particles and other highly toxic substances. At the same time, you can pay attention to the Longer products (cover) in the follow-up.
4. The high-energy diode laser beam can produce extremely high temperatures and significant amounts of heat as the substrate material is burned away while engraving and cutting. Some materials are prone to catch fire during cutting operations creating flame, fumes and smoke.
5. Although the Ray5 40W has a built in flame sensor, this technology should NOT be considered 100% accurate and should be seen only as a warning system.

P.S. During the working process of Ray5 40W, if a flame is found, the machine will stop the laser and make a sound to indicate abnormal conditions. Please pay attention to the working status of the machine.
6. During operation to ensure that any flare ups flame are properly contained and extinguished.

LASER ENGRAVER INTRODUCTION

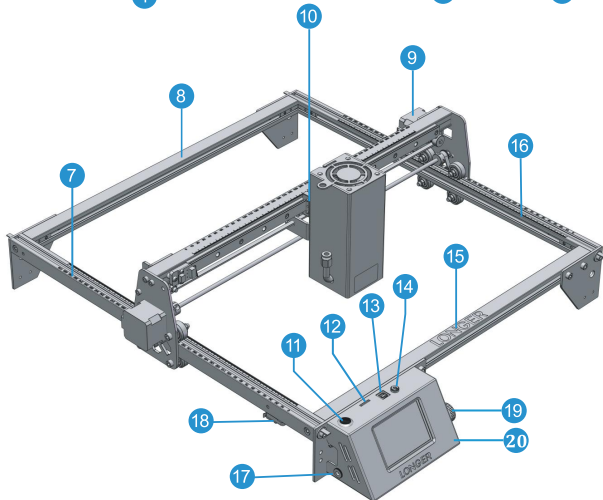
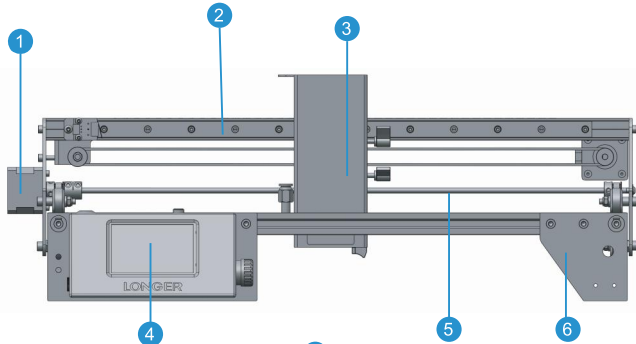

- 1 Y-Axis Motor
- 2 X-Axis Frame
- 3 Laser Module
- 4 Touch Screen
- 5 Synchronous Shaft
- 6 Support Feet
- 7 Left Frame
- 8 Rear Frame
- 9 X-Axis Motor
- 10 Laser Holder
- 11 Power Switch
- 12 TF Card Port
- 13 USB Port
- 14 Air Pump Port
- 15 Front Frame
- 16 Right Frame
- 17 Power Port
- 18 Limit Switch
- 19 E-Stop
- 20 Control Box

PACKING LIST

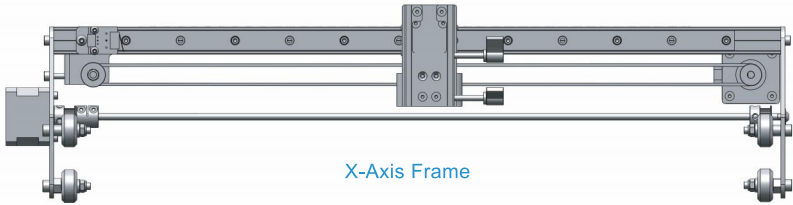

X-Axis Frame

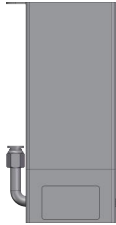

Laser Module

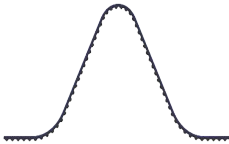

Timing Belt



Limit Switch



Air Pump



Silicone Tube

③ Rear Frame



Power Cable

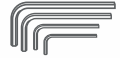

Allen Wrench



Goggles



USB Cable



M5*10X4



Wrench



M5*16X7



M5*20X4



Plywood



Support Feet



Corner Groove X4



Flat Washer X4



Control Box



Card Reader
& TF Card



Antenna



Cable Tie



Wooden Brush

① Front Frame

LONGER

④ Left Frame

② Right Frame

INSTALLATION STEPS

1

Place the profiles on a flat table in order, and place four corner grooves into the profiles referring to diagram. ▼

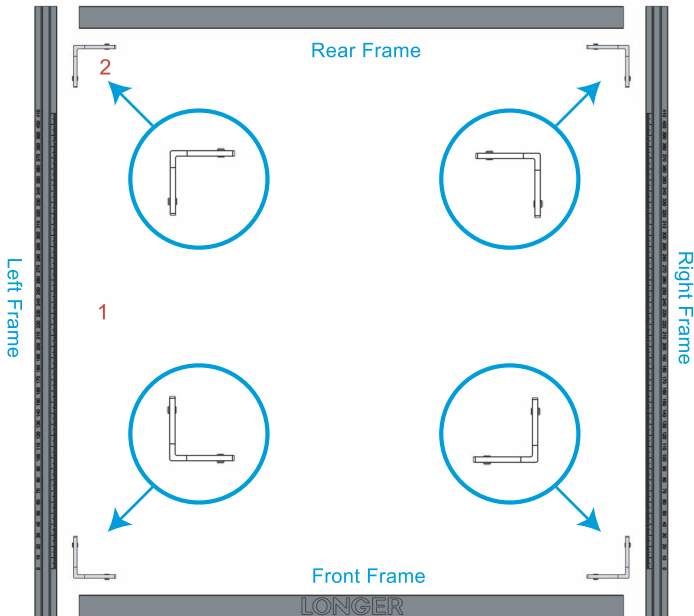

- ▼ Tighten the M5*20 screws into frames.
Tighten the M4 screws on the corner grooves.

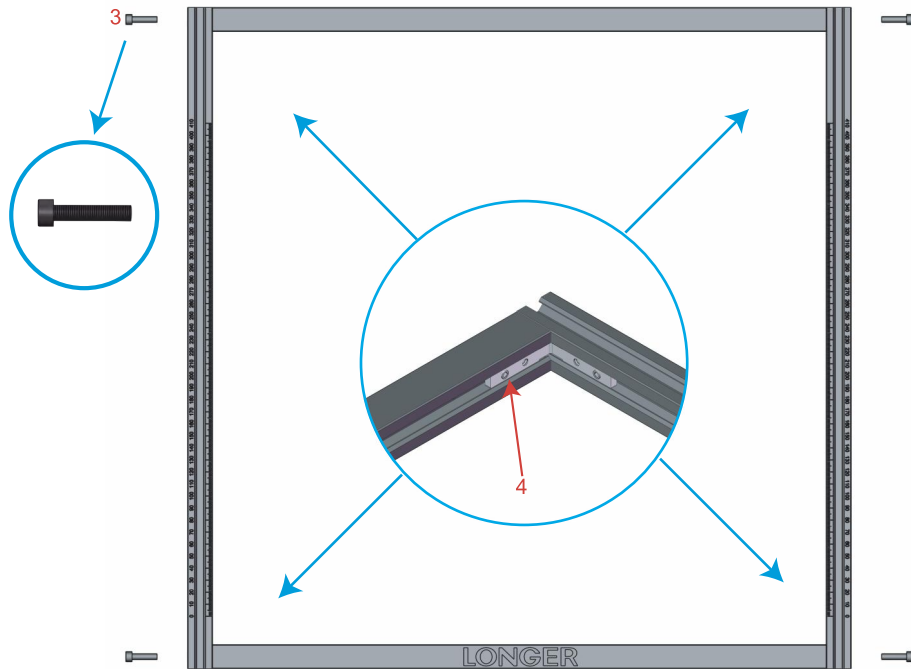

2

Preparation:

X-Axis Frame, and the frame to complete the assembly.

Install the X-Axis Frame in the V-groove of the left and right Frames along the direction of the arrow.

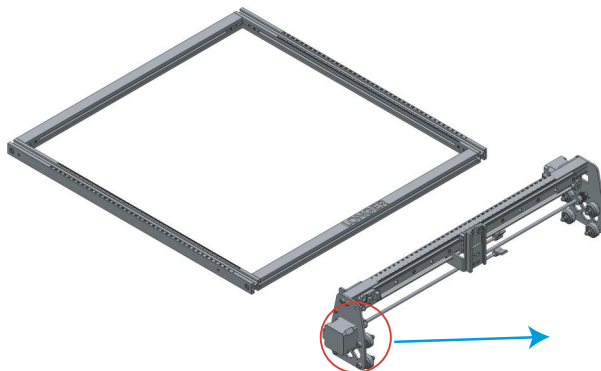
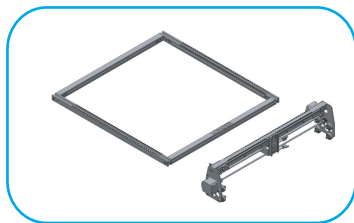

Pay attention to adjusting the eccentric nut to prevent the roller from being damaged by the groove. ▼

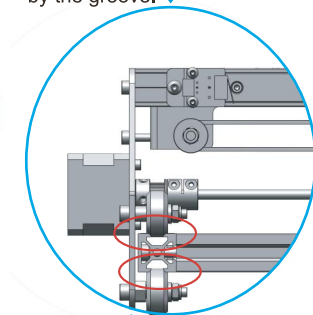

Eccentric nut

3

Preparation:

Preparation: Support feet x3, engraving machine control box, M5*16 hexagon socket cup head screw x7, antenna.

According to the figure, install the supporting foot, the control box of the engraving machine, and the antenna in the corresponding position.

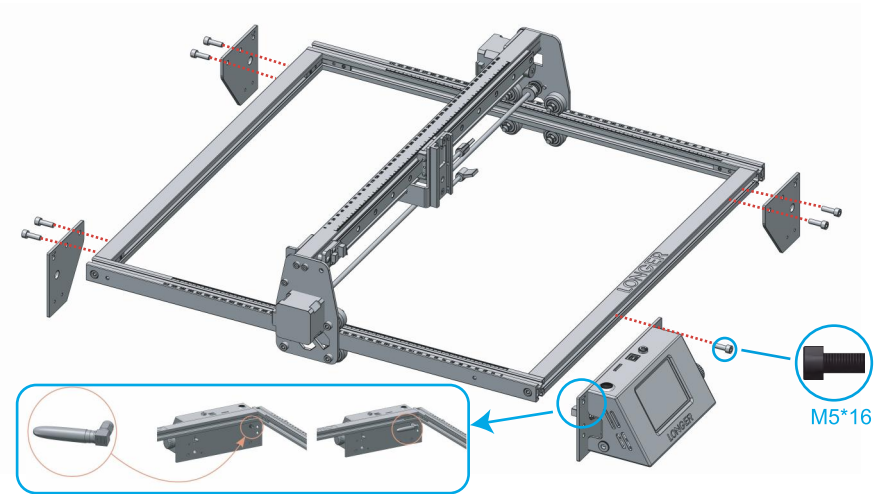
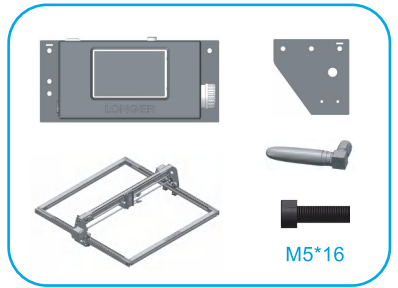

4

Preparation:

Flat washer x4, Timing belt x2, Limit Switch, M5X10 hexagon socket head screw x4.

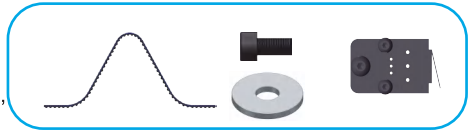

- Place a timing belt along the red arrow with the tooth face down.
- Put the flat washer on the M5X10 screw, press the timing belt with the flat washer and tighten the screw.
- Tighten the belt by hand, then fix another end of belt in the manner of previous step.
- Fix another belt on left frame in the same way.

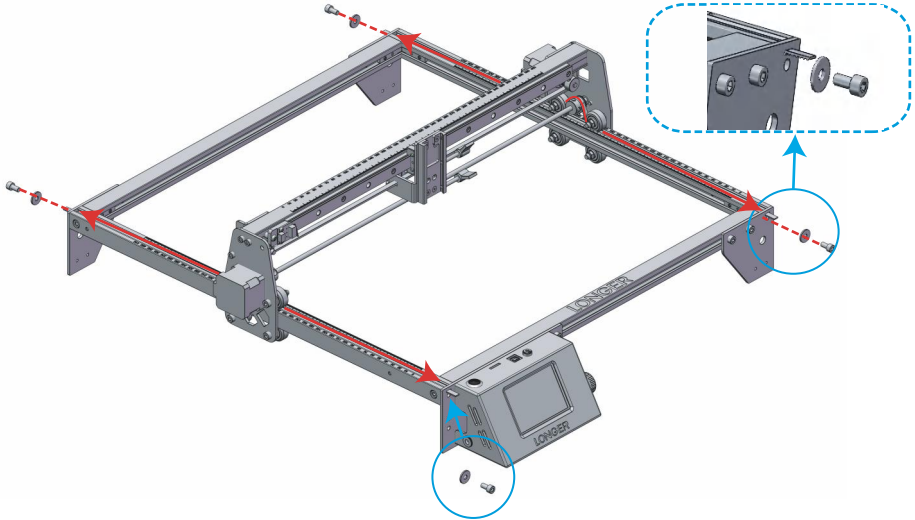

Note: When securing the timing belt, do not allow the screws and flat washers to over-press the timing belt to avoid damaging the timing belt.

e). Turn the Ray5 40W engraver over, attach the limit switch to the edge of the label, and fasten it with a hex key allen wrench, then limit switch is about 52mm from the left sheet metal.

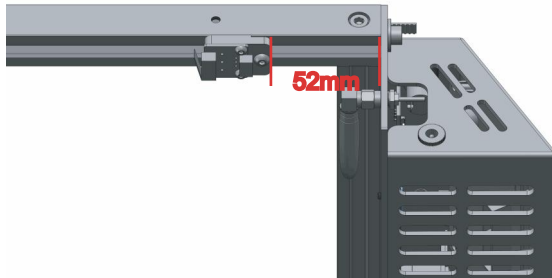

Note: Please install the limit switch attached with label, otherwise it will affect the engraving size or cause the laser head module to collide with the profile when homing.

5

Preparation:

Laser module

First install the laser module on the X-axis frame, then tighten the M4*20 handle screw clockwise to fix the laser module

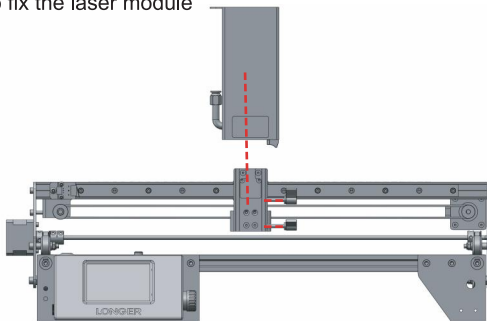

- 6 As shown in the figure, connect the cables of the control box to the motor, limit switch and laser module. Connect one end of the silicone tube to the laser module and the other end to the air pump. Finally, plug the air pump terminal into the control box port.

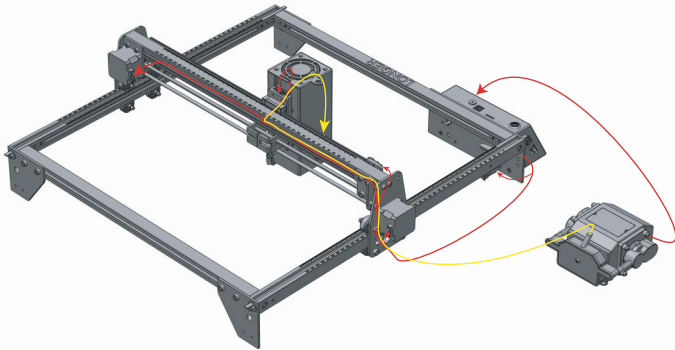

Note: Move the laser module to the upper right corner and use the velcro on the side of the metal plate to secure the cable and silicone tube. Please leave enough cable and silicone tube length to ensure that the laser module can move freely within the maximum engraving range.

7

Adjust laser focus:

Pull out the focusing block, loosen the M4*20 handle screw, move the laser module down, tighten the M4*20 handle screw when the bottom of the focusing block touches the plywood, and close the focusing block

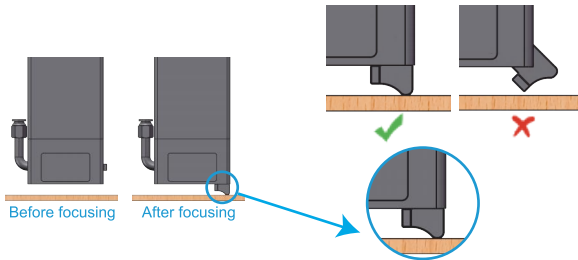

Please reference more details on digital manual in TF card about the operation of Laser Engraver and installation of LaserGRBL or LightBurn.

- * Before using the engraver, please rotate it clockwise to release the emergency stop switch, otherwise the Ray5 40W cannot be powered on normally, **and be careful not to rotate the emergency stop switch counterclockwise to avoid damage.**

LaserGRBL SOFTWARE OPERATION

1

Download

- a) Download LaserGRBL from the following link: <https://lasergrbl.com/download/>
- b) Double click the software installation package to start the installation process. Click 'Next' until the installation is completed.

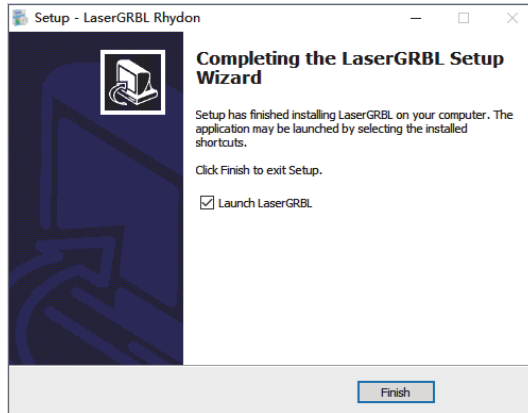

- c) Once LaserGRBL is installed, rotate emergency stop switch clockwise, press the power switch button, power up the Ray5, and connect the laser engraver to computer via data cable.

2 Install CH340 driver

If you cannot find the correct port, install the CH340 driver manually by clicking Menu > Tools > Install CH340 Driver. After installation, restart your computer.

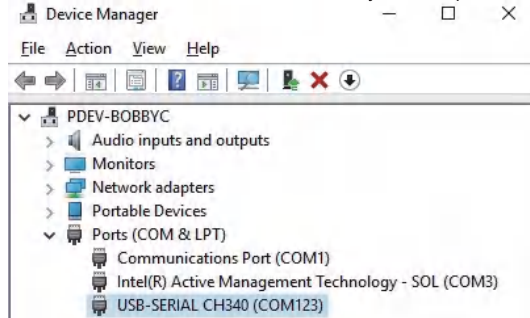

3 Usage

a) First, click the 'File' button, then select 'Open File' to choose the file you want to engrave.

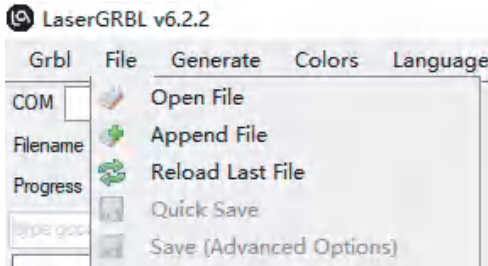

b) After opening the file, set the Quality value to 10 lines/mm for high efficiency.

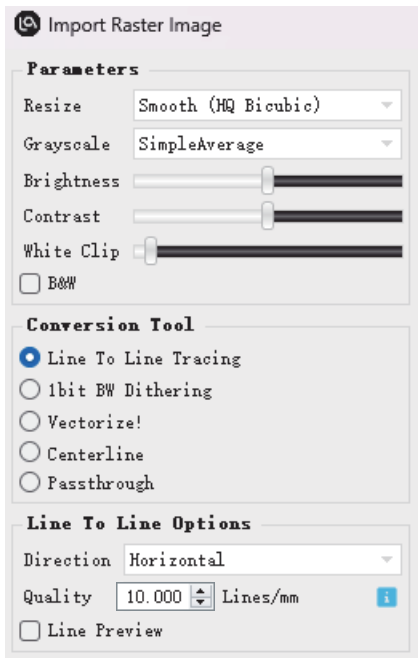

c) After clicking the Next button, adjust the speed and power values in this window according to parameter table. The S-MAX value should be ten times the actual power. Then, click Create.

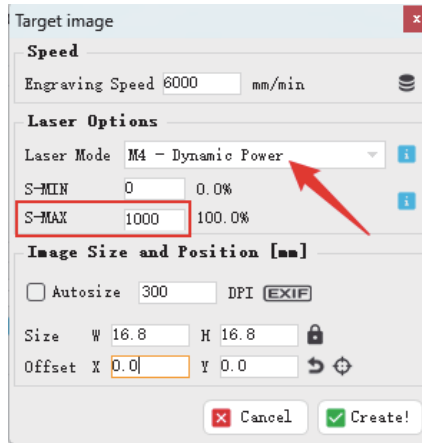

d) Select correct port, set the baud rate to 115200, connect to Ray5 40W, click the start button.

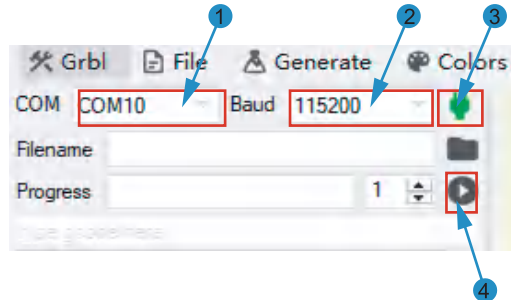

For more help with LaserGRBL, please refer to the link: <https://lasergrbl.com/usage/>

LightBurn SOFTWARE OPERATION

1 Setup

- Download Lightburn from <https://lightburnsoftware.com/download/> and double-click to install it.
- Download the 'RAY5_40W.lbdev' file from SD card.
- Click on Settings, then change the unit to mm/min.
- Set 'Laser on when framing' to 2.00%, select 115200 for 'Baud rate', and click 'OK'.

untitled> - LightBurn 1.2.01

Edit Tools Arrange Laser Tools Window Language

Settings

Device Settings

Machine Settings

Units / Grids

Better for CO2

mm / sec

Inches / sec

Inches / mm/sec

Better for diode

mm / min

Inches / min

Inches / mm/min

Other options

Auto-home on startup

Fast Whitespace Scan

0 mm/min

Enable \$J Jogging

Enable DTR signal

Enable laser fire button

Laser on when framing 2.00%

Enable 'Out of Bounds' warning

Enable GCode Clustering

Return to Finish Position

X: 0.0mm

Air Assist

M7

S-value max 1000

Baud Rate 115,200

Transfer mode Synchronous

- Upon launching LightBurn for the first time, the New Device Wizard will prompt to help you set up the machine. Click 'Import'.

Find My Laser Create Manually LightBurn Bridge **Import**

Make Default Edit Emere Export

Import Preferences

OK Cancel

Select the 'RAY5_40W.Ibdev' file and click 'Open', Choose 'RAY5_40W' from device list and click 'OK'.

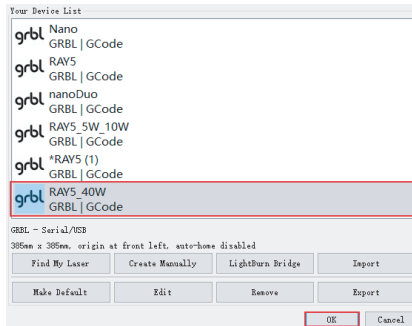

e) If no ports are listed in the drop-down menu, it means no engraver is detected. This could be due to the engraver not being plugged in correctly, not powered on, or the PC missing a driver. You will need to download and install the CH340 driver. It is recommended to use 'absolute coordinates' when engraving

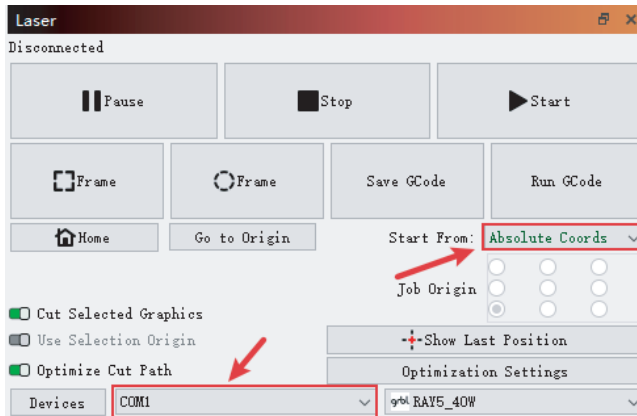

2 Import graphic

- Click File > Import
- Open the project you want to carve

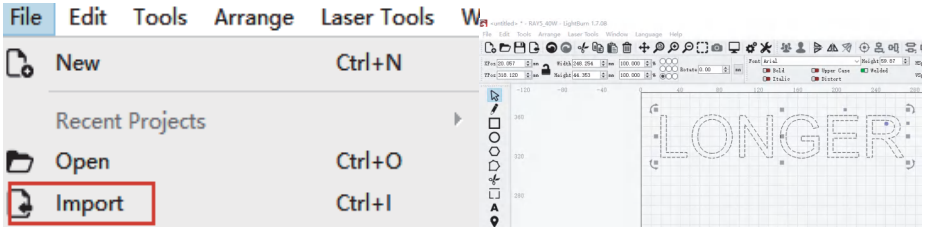

3 Setting parameters

- Double-click the layer.
- Modify the laser power and speed according to the parameter table, set 'Interval' to 0.1 mm for high efficiency. Enable air if it needs to turn on the air pump.

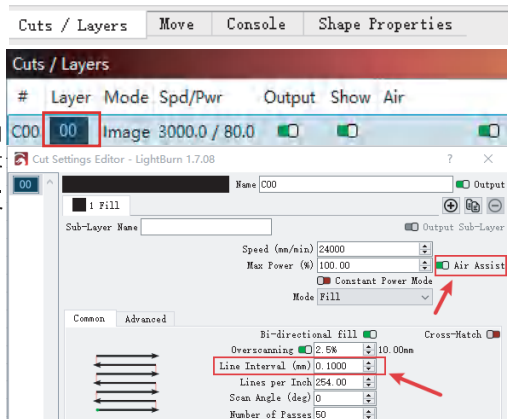

4 Prepare to engrave

a) Select the graphic, then click 'Frame', to confirm the carving position, and then click 'Start'.

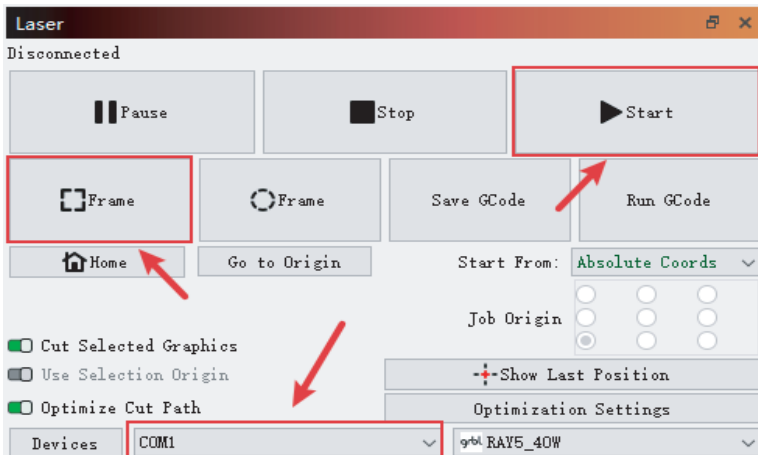

For more help with LightBurn, please refer to the tutorial at: <https://lightburnsoftware.com/pages/tutorials>.

LaserBurn APP Operation

1 Connect to WiFi in AP mode

a) Open the WLAN settings on your phone, search for the WiFi network starting with LongerLaser_XXXX and input the password 12345678 to connect to the Ray5 40W WiFi.

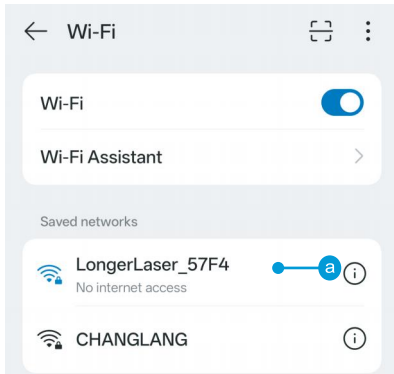

b) Return to LaserBurn and go to the Home page, then click the Not Connected icon.

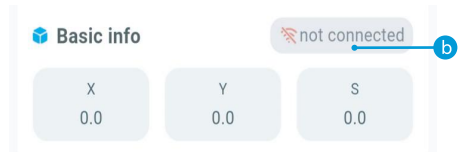

c) Enter the IP address 192.168.0.1
d) Click Connect. A message will appear saying 'Connection Succeeded' when the connection is successful.

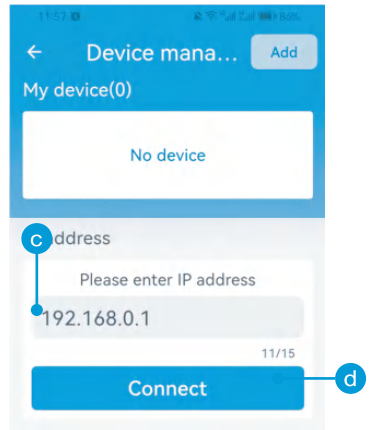

2 Connect to WiFi in STA mode

a) Open the WLAN settings on your phone. Run LaserBurn and go to the Home page, then click the Not Connected icon.

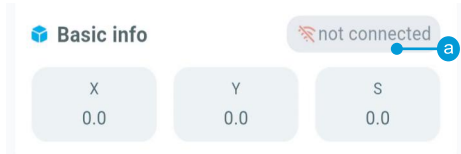

b) Enter the network configuration page, then click Add in the upper right corner.

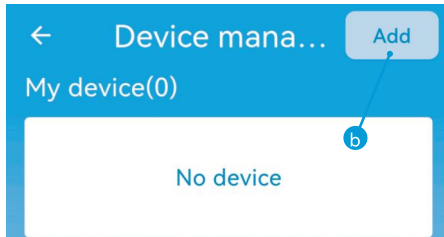

c) Click Scan device .

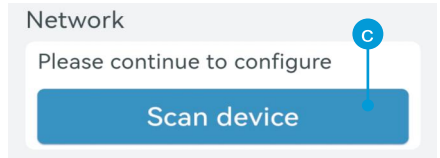

d) Search for the WiFi network starting with LongerLaser_XXXX and input the password 12345678 to connect to the Ray5 40W WiFi.

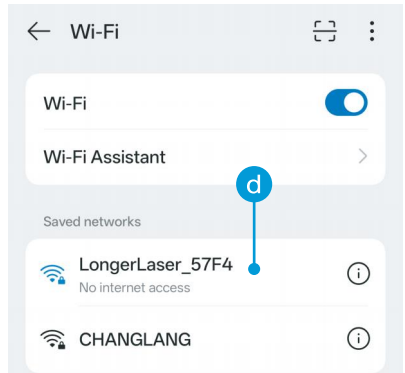

e) After the connection is successful, return to LaserBurn select Set STA mode.

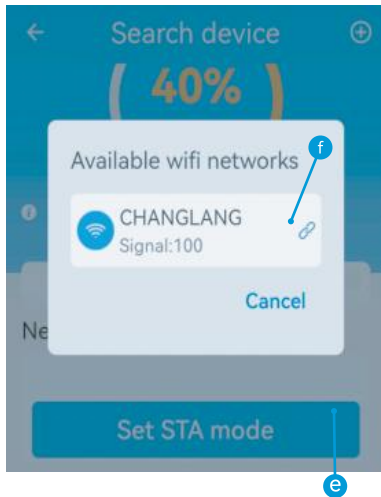

f) Connect to the router's WiFi (only supports 2.4G), and enter the password.

g) Go back to LaserBurn, click 'Connect network' at the bottom of the page, then connect your phone to the same WiFi as the STA mode from the previous.

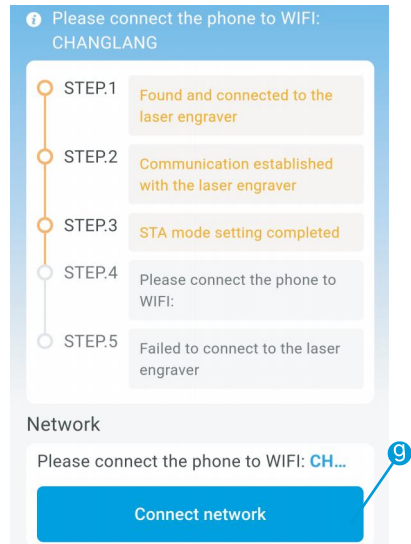

h) When the connection is successful and network process reaches 100%.

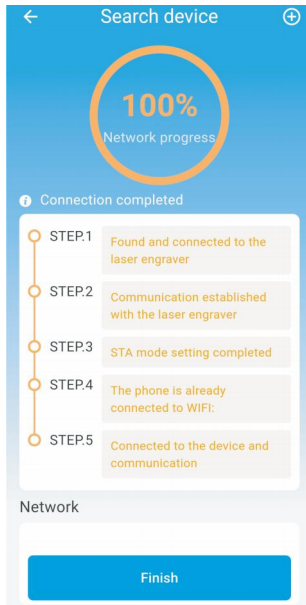

i) Click FINISH at the bottom to return to the device list interface.

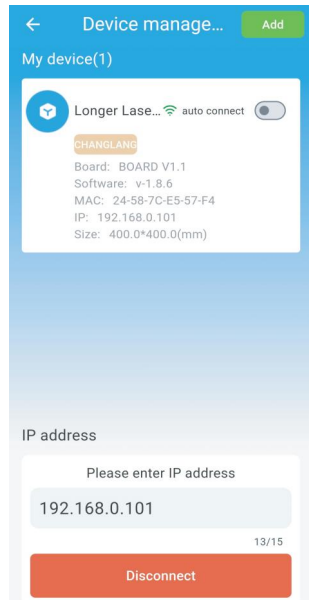

3 Make a project

a) Run the LaserBurn app, connect it to the Ray5 40W, add a graphic, and click 'Edit' to set the size and position.

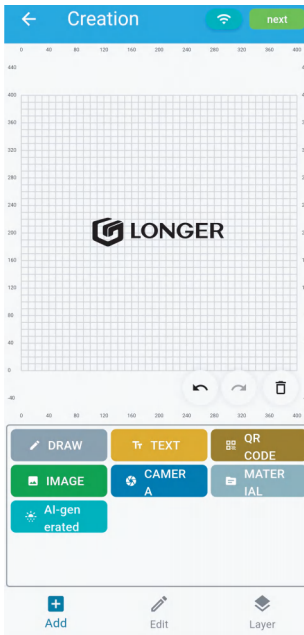

b) Click 'Layer' to set the parameter of the graphic, then click 'next' in the upper right corner.

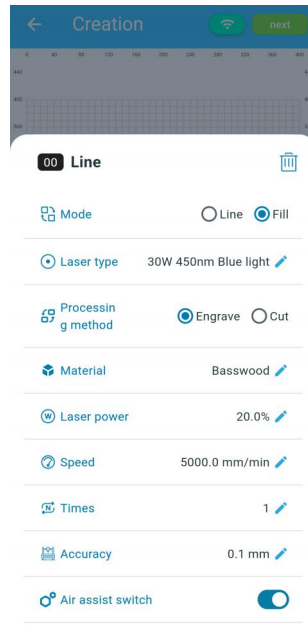

c) Click 'Next' to enter the engraving preparation page, Click 'Border setting' to set the speed and patrol power. After setting, click 'frame' to patrol the border. After confirming the engraving position, click 'Start' to engrave.

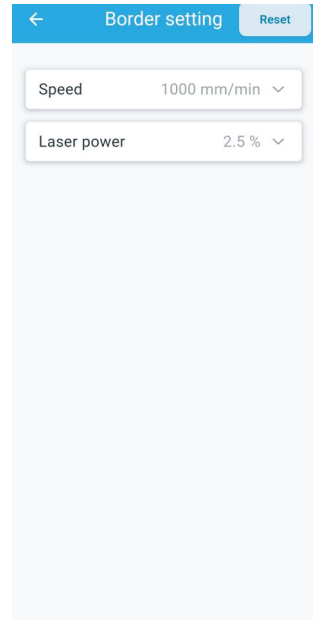
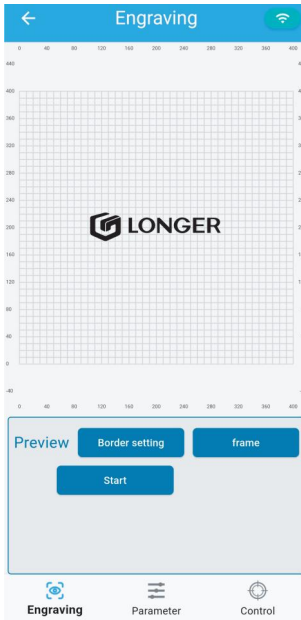

d) After confirming that the focus is adjusted normally and the goggles are worn, click 'Confirm' .

 **Warning**

Please check the focal length.

Don't remind me again

Cancel | **Confirm**

 **Warning**

Be sure to confirm that the laser work area is safe.
Be sure to wear goggles and install a protective cover.

Don't remind me again

Cancel | **Confirm**

e) Click 'Comfirm' to make sure the file name, and then the file starts to upload to the Ray5 40W. After the upload is completed, Ray5 40W will start engraving task.

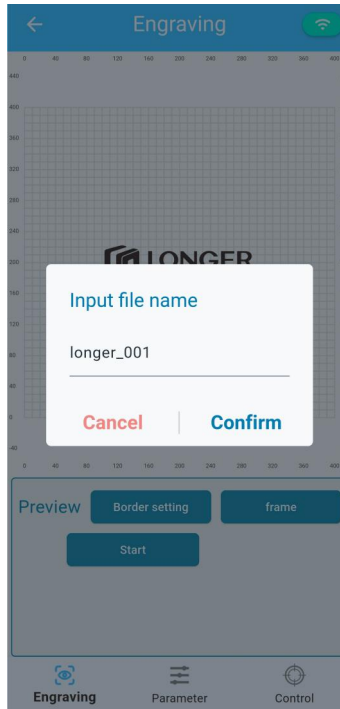

f) The APP will display the task progress.

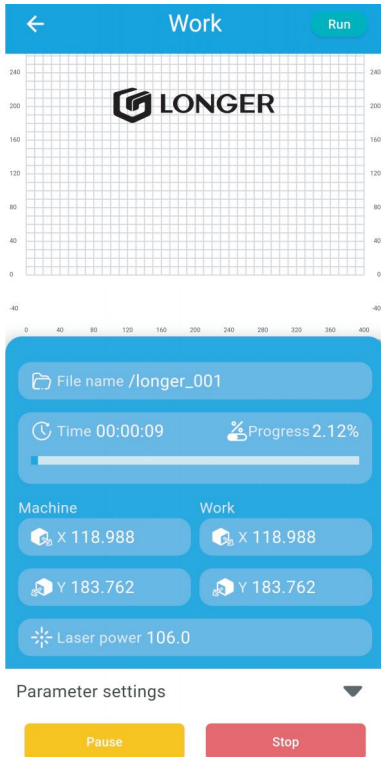

g) When task is completed, there will be a Work completed prompt. Click 'Confirm' to return to Home page.

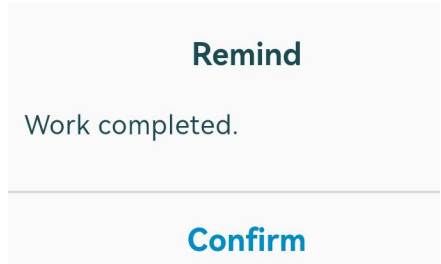

WARRANTY

- To the extent permitted by law, this warranty is exclusive and replaces all other warranties, whether express, implied, or statutory, including but not limited to warranties of fitness for a particular purpose or any statutory provisions. Longer Technology is not responsible for any incidental, special, indirect, or consequential damages arising from use, misuse, incompetence, or product defects.
- Consumers applying for warranty service are responsible for backing up all important personal data in advance.
- During maintenance, such as part replacement or software updates, data may be lost. Longer Technology does not provide data backup services or guarantee the integrity of related data and settings.
- Different warranty periods apply to the laser unit, consumables, and wear parts. For details, please refer to: <https://www.longer3d.com/pages/warranty-policy>. However, the warranty does not cover the following situations:
 - 1) Failure or damage is caused by incorrect or improper use, maintenance, or storage, including but not limited to improper handling, use beyond its intended purpose, incorrect plugging or unplugging of external devices, drops, external impacts, exposure to extreme temperatures, solvents, acids, alkalis, water intrusion, pest infestations, or foreign object damage to components (such as housing, wiring, etc.).
 - 2) Failure or damage caused by unauthorized installation, repairs, modifications, additions, or disassembly by individuals or agencies not authorized by Longer Technology.
 - 3) Modification, alteration or removal of the original identification information of the product or components.
- Processing quality is influenced by user operation, material selection, and environmental factors, and is not covered under warranty.

- The copyright for this manual, as well as the software and hardware associated with this product, is owned by Shenzhen Longer Technology Co., Ltd. (here after referred to as Longer Technology). 'Longer' is a registered trademark of Longer Technology.
- The information in this manual is subject to change without notice and does not constitute a commitment by the company. For the latest updates, please visit our website. <https://www.longer3d.com>.
- Except for the personal use by the purchaser, no part of this manual may be rewritten or reproduced in any form or for any purpose without written permission from Longer Technology.

MORE INFORMATION ▼



Support Email : support@longer.net



Facebook ID: Longer Global



Facebook Group: Longer Laser Engraver Official Group



Youtube channel: Longer Official

Shenzhen Longer Technology Co., Ltd.

We provide global online technical support services. If you encounter any problems, please contact us.