

AlgoLaser **Pixi**

QUICK START GUIDE

Smart Laser Engraver with Enclosure



Always read the instructions before you start.

Versions: A-01

ENGRAVING/CUTTING HAPPINESS

Thanks for choosing AlgoLaser!

We are so glad that you give it a home.

We have packed everything into the neatest form, utilizing laser engraving/cutting machines, to help you enjoy engraving/cutting, achieve the greatest yield, and realize your dream.



The Founder of AlgoLaser

After-Sales Policy

- **12-Month Limited Warranty**

We provide 12 months warranty for every product from the date of purchase against defects in materials and workmanship. And we will offer repair or replacement service according to the product condition. Please note that this warranty does not cover damaged product caused by misuse or abuse.

- **Return or Exchange Policy**

For detailed policy, please refer to the return and exchange policy on the platform you purchased from.

- **Misdelivery & Missing Parts**

If you receive an incorrect product or discover missing parts after receiving the product, please contact our customer service. AlgoLaser will cover the shipping cost of the incorrect product or send the replacement parts.

- **Troubleshooting Support**

AlgoLaser offers online troubleshooting guides that helps you to solve problems step-by-step. Please reach algolaser.com to get tutorial videos, FAQs, and tech support from professional engineers.

After-Sales Support

① Please go to <http://algolaser.com/support/> to submit your inquiry. To help engineer make faster judgment and provide effective solutions, please provide related pictures and videos within the inquiry.

② Information needed:

Machine Model

Laser Module

Purchase Channel

Delivery Date

Computer System

Software

Problem Description, Video & Photo

③ After submitting, our engineer will reply to you within 24 hours.

CONTENTS

01

Before You Start

1.1 Disclaimer and Safety Guidelines -----	1
1.2 Item List -----	5

02

Get to know -----	7
--------------------------	---

03

How to Use

3.1 Unboxing and Preparation -----	11
3.2 Connect the Smoke Pipe -----	14
3.3 Power the Machine -----	16
3.4 Place the Material -----	17
3.5 Focus -----	18
3.6 Start Engraving/Cutting -----	21
3.7 Adjust Machine Height -----	21
3.8 Main Port Definition -----	25
3.9 Operation and Status of the Machine -----	25
3.10 How to Use AlgoOS -----	26
3.11 How to Connect Pixi to APP via WiFi -----	47
3.12 How to Connect the Machine to a PC -----	53

01

Before You Start

1.1 Disclaimer and Safety Guidelines

1. The laser engraver emits laser light. Placing any living body under the laser emission port (marked with an orange warning sign) is strictly forbidden.
2. Patients with photosensitive epilepsy are prohibited from using or approaching the laser engraver.
3. Pixi complies with the laser safety certification IEC-60825-1 Class 1 standard. Please make sure to use the product correctly according to the user manual. Do not directly touch or observe the laser to avoid accidental injury. Additionally, the machine should be monitored throughout its operation. Please disconnect the power supply promptly when leaving.
4. To better protect your eyes, you may choose to purchase safety goggles on your own. When purchasing, please ensure they meet safety standards, specifically that the laser wavelength is 450nm ($\pm 5\text{nm}$) or above and the protection level is OD4+ (Optical Density).
5. Avoid placing flammable materials near the laser engraver. When the laser engraver is running, closely observe it and avoid leaving it unattended to prevent the engraved objects from catching fire. Set up the laser engraver in a fireproof area and ensure proper ventilation. If possible, we recommend purchasing a fire extinguisher and keeping it nearby the machine.
6. Ensure there is enough space when operating the laser engraver. Engraving certain materials may produce smoke, so it's important to use exhaust equipment to vent the smoke out.
7. When the machine is running, avoid letting your body or other objects touch the laser beam, as this may cause serious bodily injury or beam reflection. Do not touch the radiator, as it may still be hot even after the laser engraver has stopped working.
8. Do not allow children or teenagers to use the laser engraver alone, especially children under the age of 14. Adult supervision is required at all times.
9. The operating temperature range of the machine is 0°C to 40°C.
10. The use of the laser engraver carries a significant risk of fire. When operating the machine, please ensure that someone is available to handle any potential fire emergencies at all times.





Caution-Use of controls or adjustments or performance of procedures other than those specified herein may result in hazardous radiation exposure.

Wavelength:	450±5nm
Maximum output power:	3W
Laser safety level:	Class4

The laser safety classification of this product is based on IEC 60825-1:2014.
The laser safety level of laser radiation emitted Through laser aperture exceeds Class1.



Caution-Use of controls or adjustments or performance of procedures other than those specified herein may result in hazardous radiation exposure.

Wavelength:	455±5nm
Maximum output power:	5W
Laser safety level:	Class4

The laser safety classification of this product is based on IEC 60825-1:2014.
 The laser safety level of laser radiation emitted Through laser aperture exceeds Class1.



Caution-Use of controls or adjustments or performance of procedures other than those specified herein may result in hazardous radiation exposure.

Wavelength:	455±5nm
Maximum output power:	10W
Laser safety level:	Class4

The laser safety classification of this product is based on IEC 60825-1:2014.
 The laser safety level of laser radiation emitted Through laser aperture exceeds Class1.

1.2 Item List



Laser Engraver/Cutter



Allen Key



Brush



Stylus Pen
(random color)



Type-C Cable



Focal Gauge



Flange Interface



Power Adapter



Type-C to Type-A Adapter



Smoke Pipe



Metal Card



Plywood



Acrylic

Laser module

Pixi have 3 different specifications, please refer to the product model you have purchased to confirm the list.



ALM-3BD(3W)Laser Module



ALM-5BD(5W)Laser Module



ALM-10BD(10W)Laser Module

* The above images are for reference only. Please refer to the actual product.

02

Get to know

2.1 External Interface of the Machine

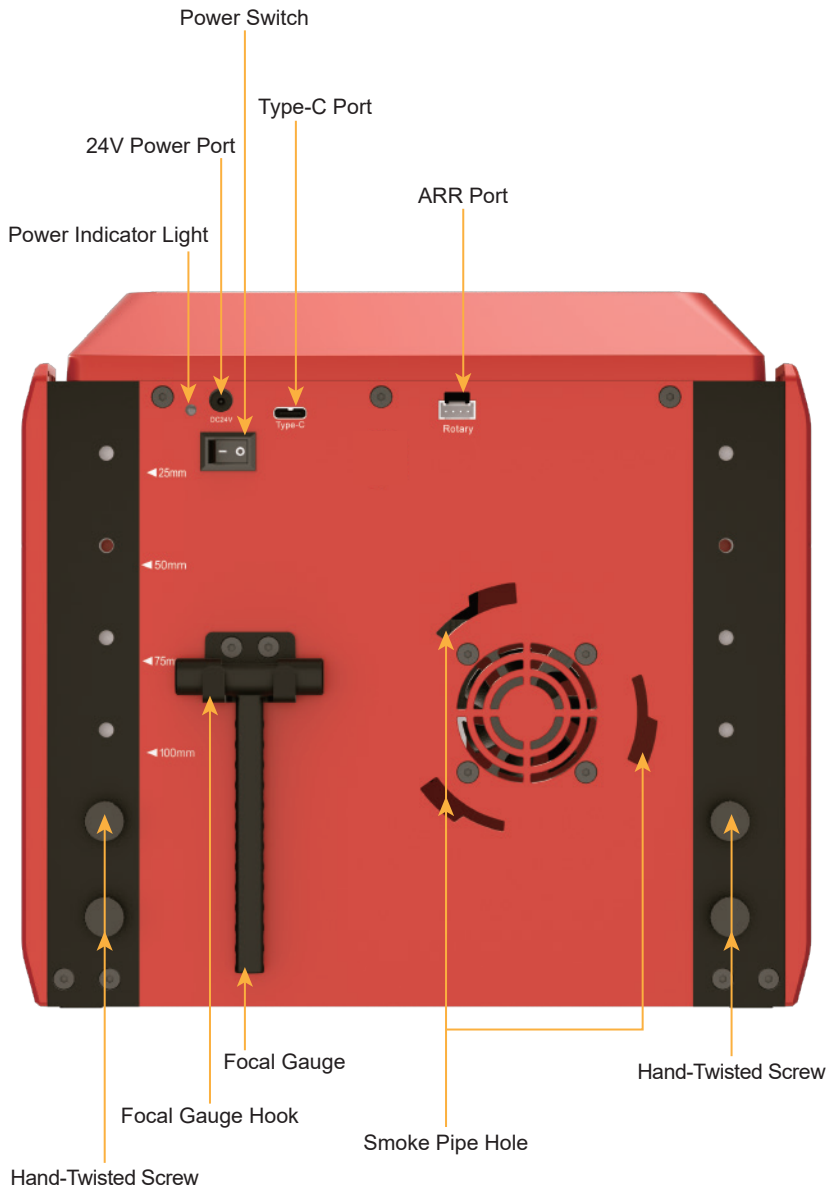

2.2 Button, Protective Lid, Top Lid Components

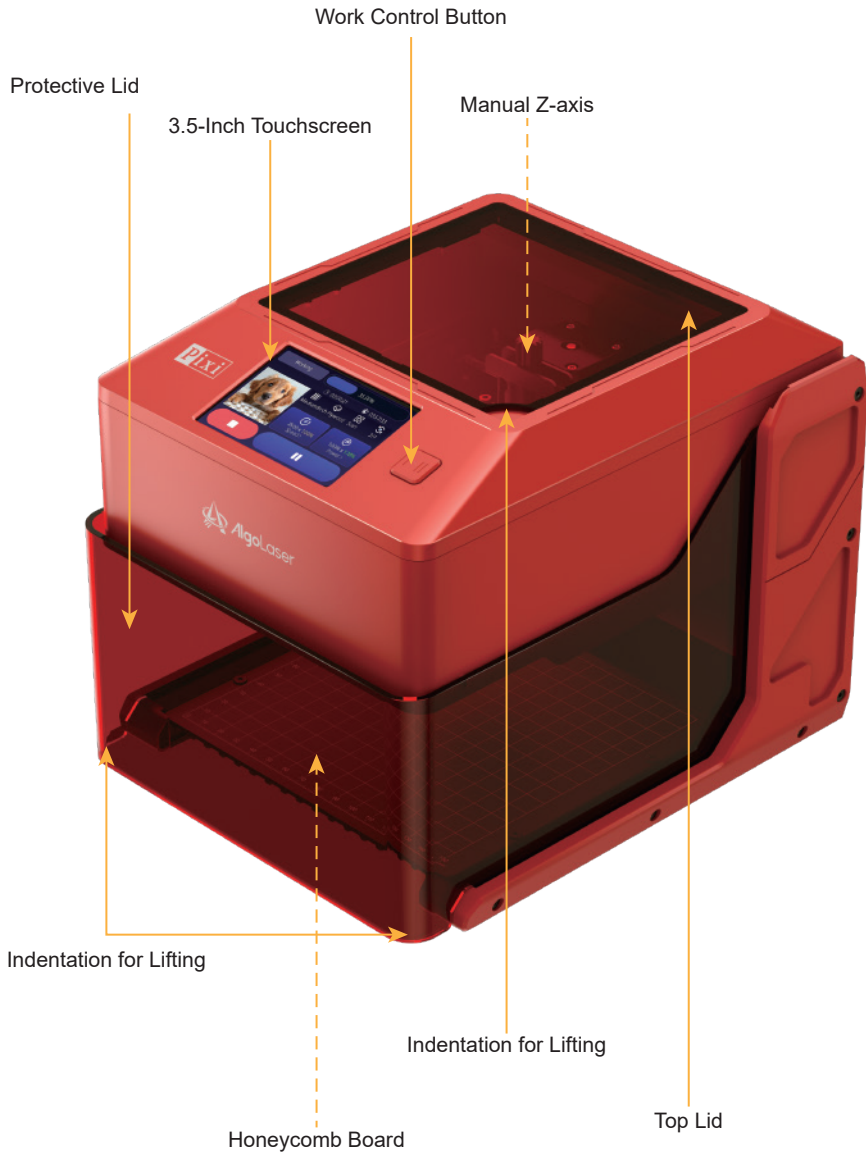

2.3 Manual Z-axis

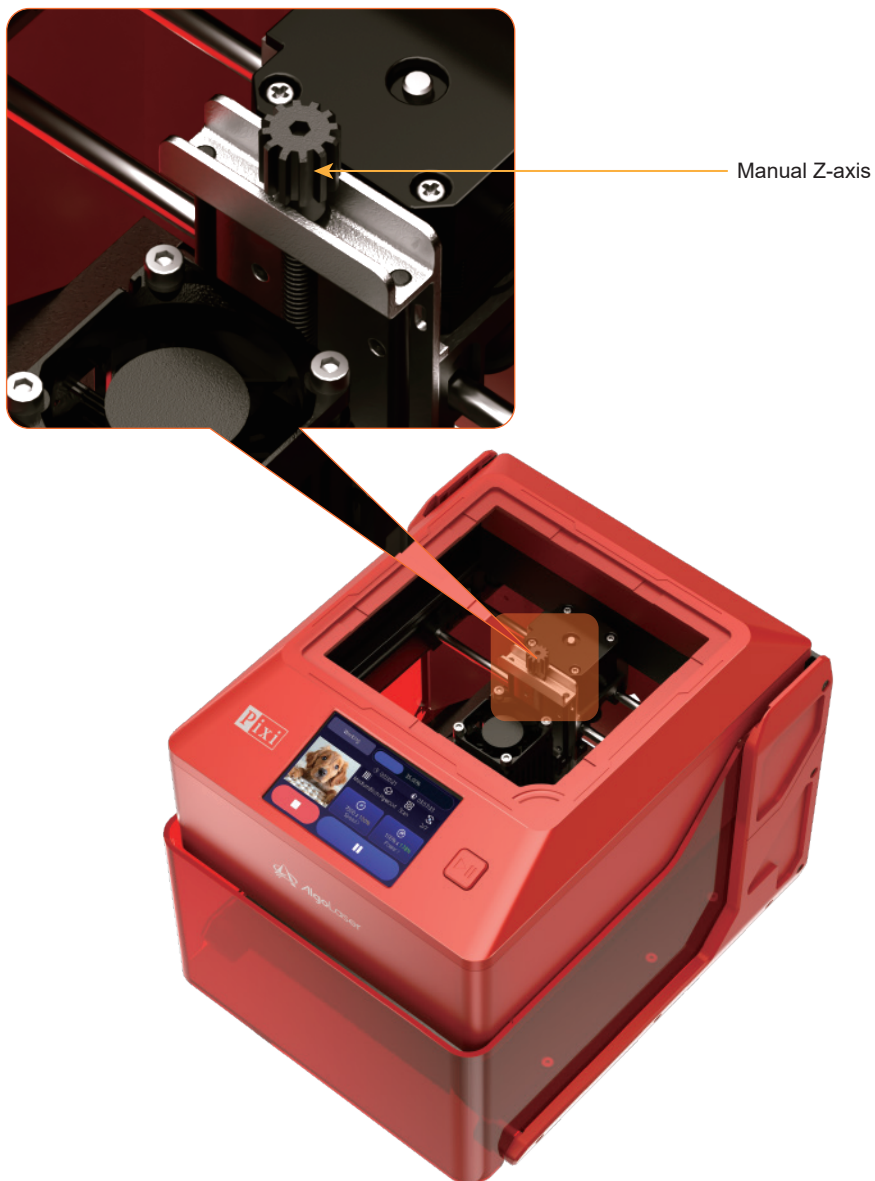

03

How to Use

3.1 Unboxing and Preparation

i. Remove the machine from the packaging.



ii. Take out the protective foam inside the machine.

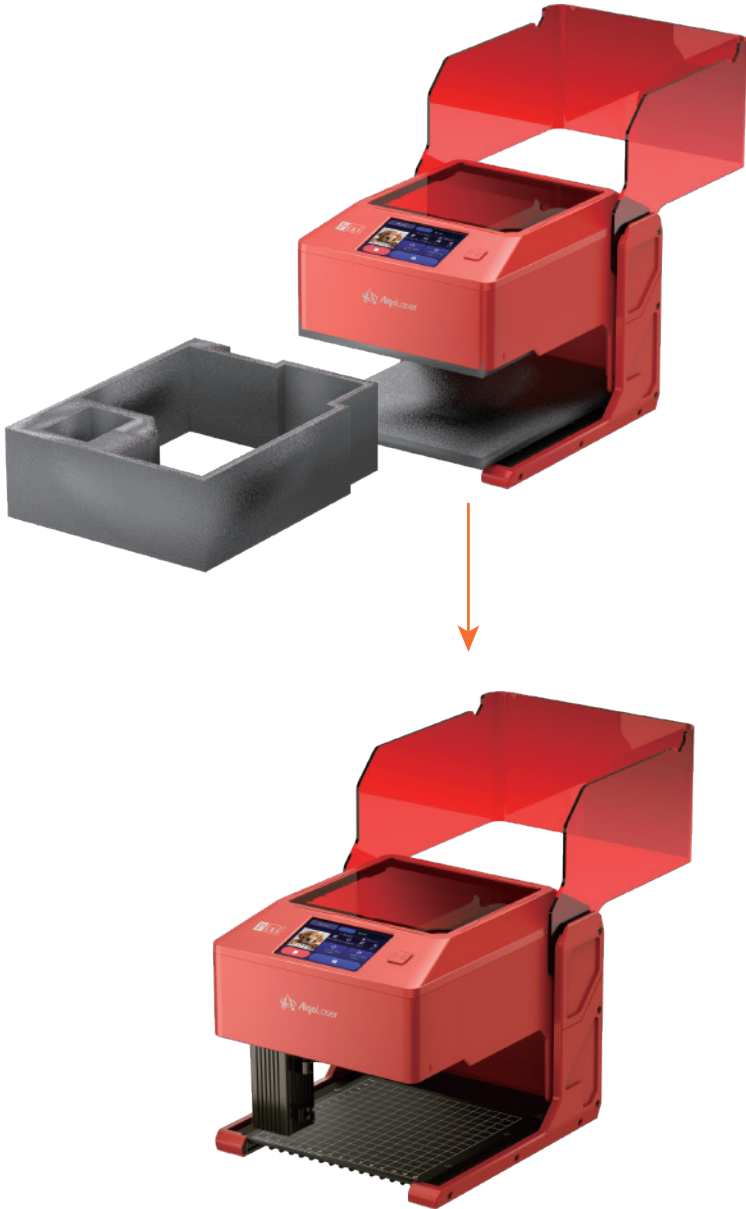

iii. Move the laser module to the center of the machine and remove the protective foam on the top of the laser module.

(Note: Ensure all foam is completely removed before proceeding with operation.)

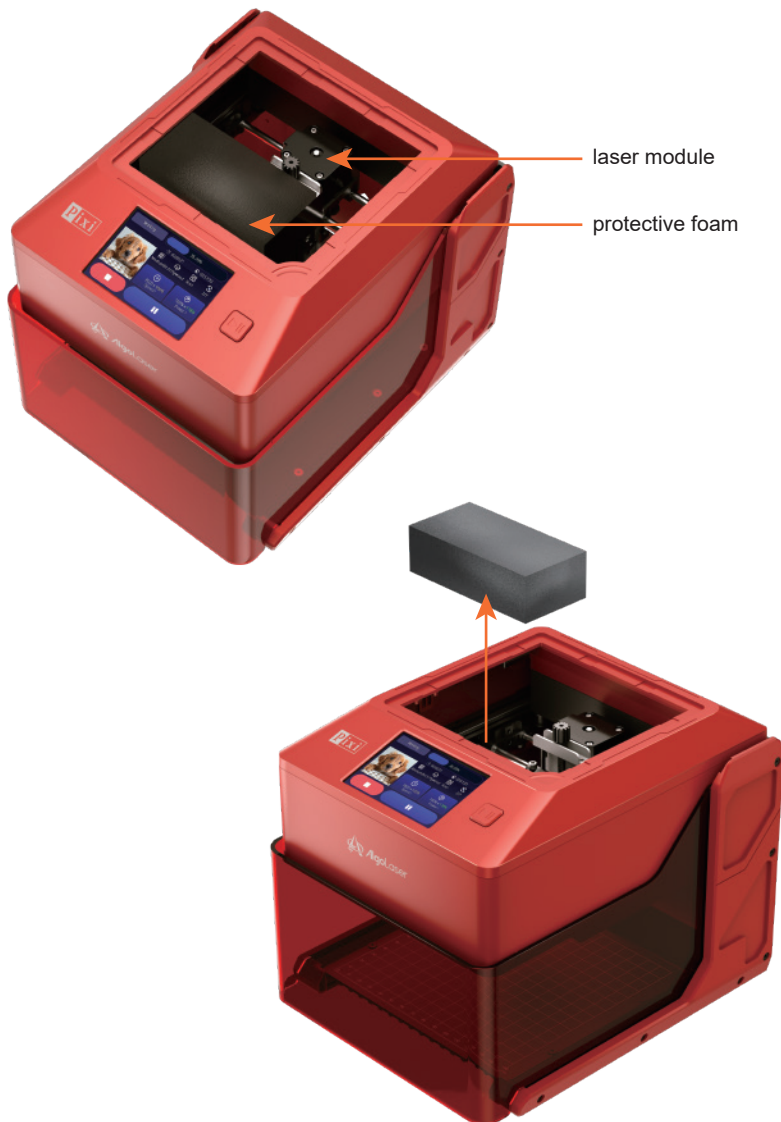

3.2 Connect the Smoke Pipe

i. Extend the contracted smoke pipe to its full length;



ii. Rotate the smoke pipe counterclockwise along the flange's limiting interface until tightly connected;



iii. Align the flange interface with the smoke pipe interface on the back of the machine, then rotate counterclockwise until securely connected to the machine;

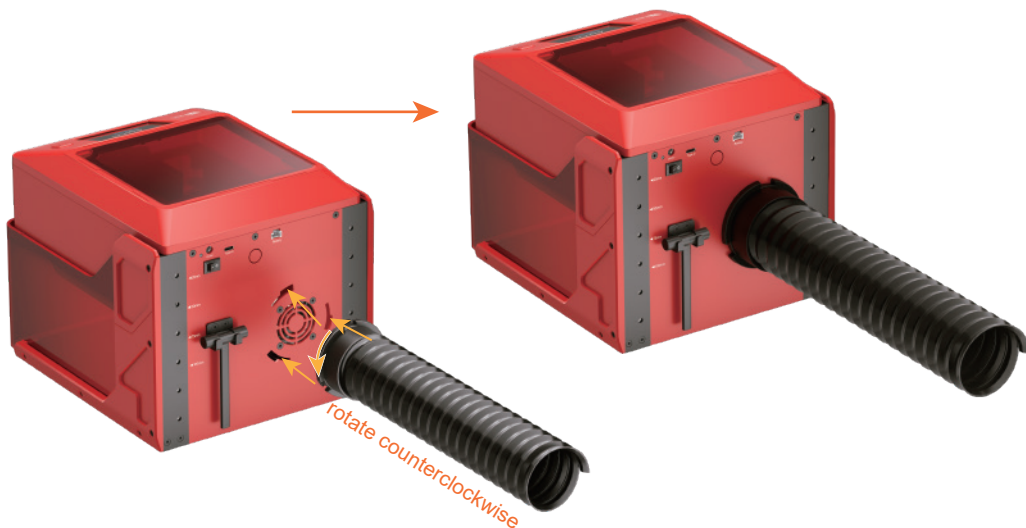

iv. Depending on your needs, connect the end of the smoke pipe to a smoke purifier or place it outside a window to effectively expel smoke and dust.

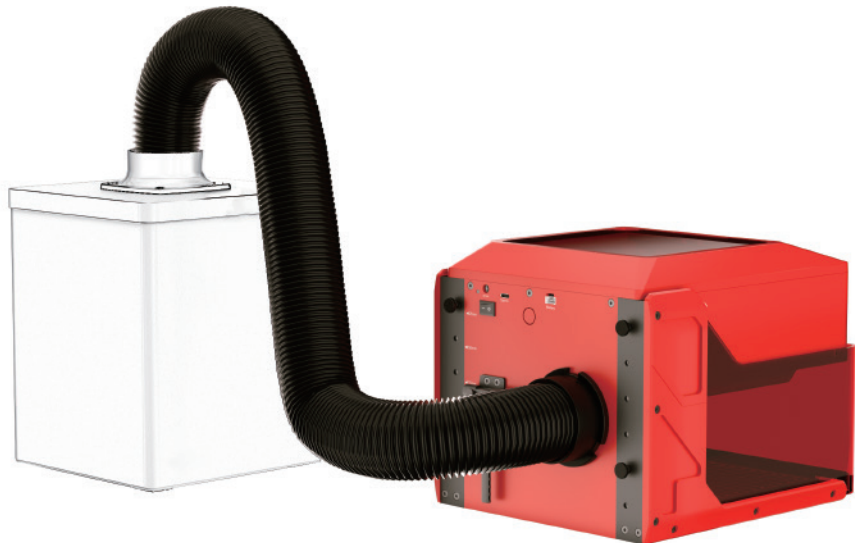

3.3 Power the Machine

i. Insert the power adapter into the socket and connect the 24VDC power to the power port. Press the power switch, and the power indicator light will turn green.

ii. The machine turns on.



①



②



③

3.4 Place the Material

- i. Lift the protective lid.
- ii. Place the engraving/cutting material on the honeycomb board (refer to the scale on the board if needed).

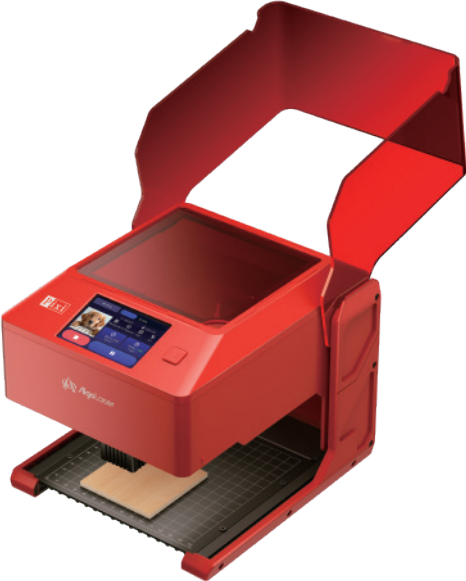
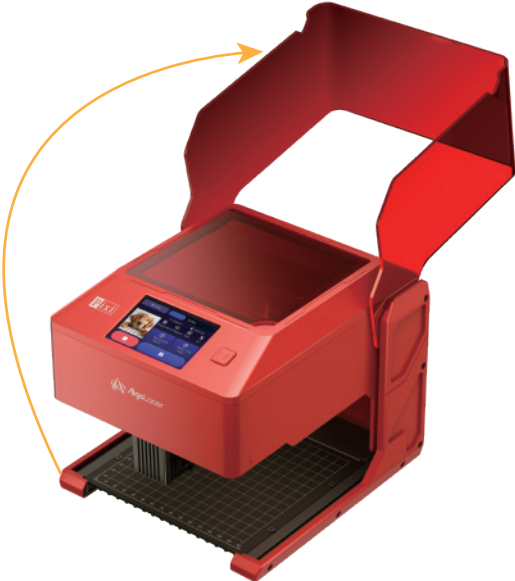

3.5 Focus

i. Place the focal gauge on the material.



ii. Open the top lid first



iii. Rotate the Z-axis knob to adjust the laser focus distance (clockwise for upward movement, counterclockwise for downward movement).

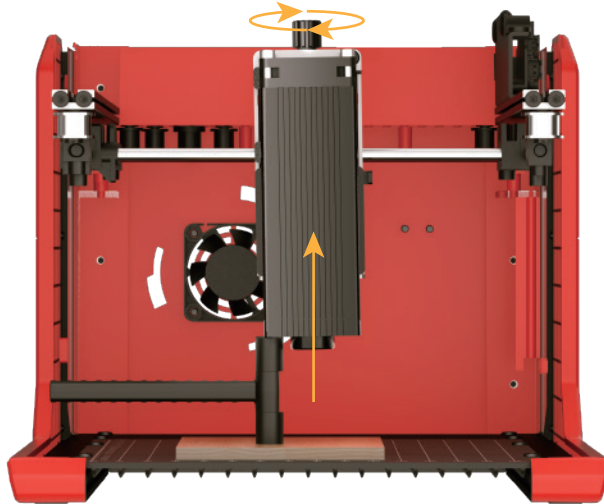

clockwise for upward movement

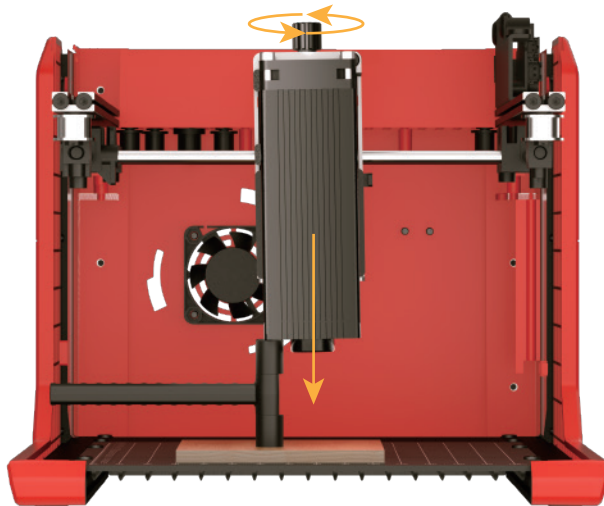

counterclockwise for downward movement

iv. Close the top lid, remove the focal gauge and lower the protective lid.

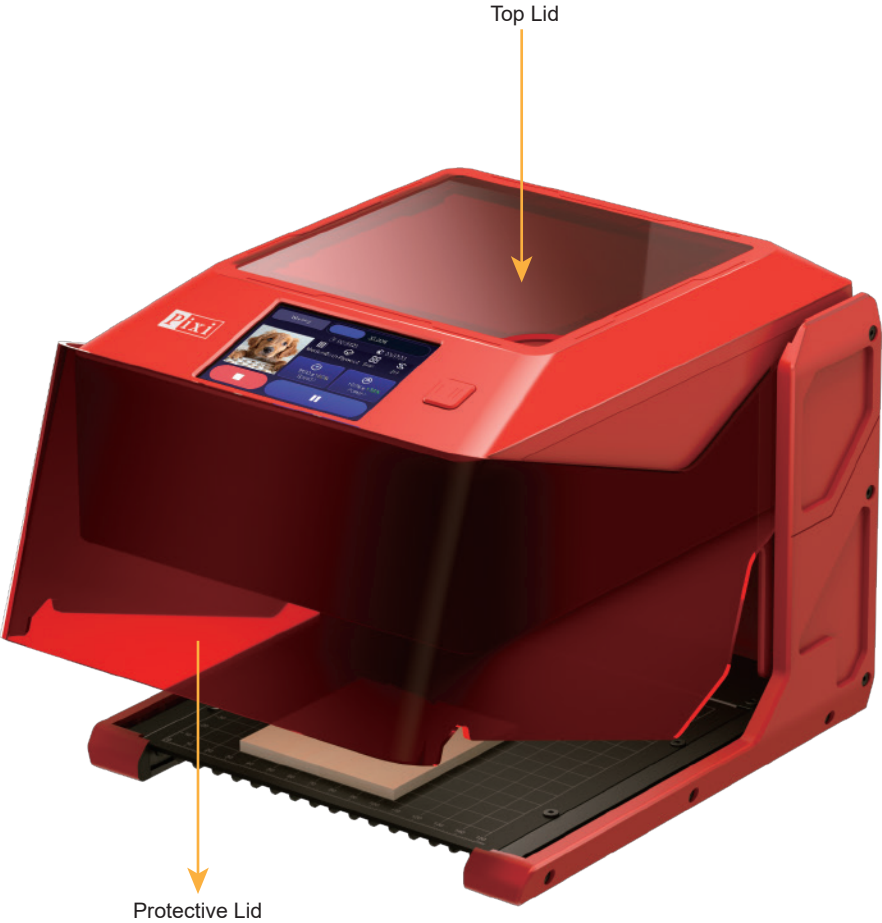

3.6 Start Engraving/Cutting

Note: For safety, ensure the protective lid is closed; otherwise, the task cannot proceed. During engraving/cutting, if the protective lid is opened, the task will be interrupted.

3.7 Adjust Machine Height

(For use with rotary rollers or engraving thicker objects.)

i. Loosen the rear screws.



ii. Tilt the machine, use both thumbs to push the back panel, and create a gap.

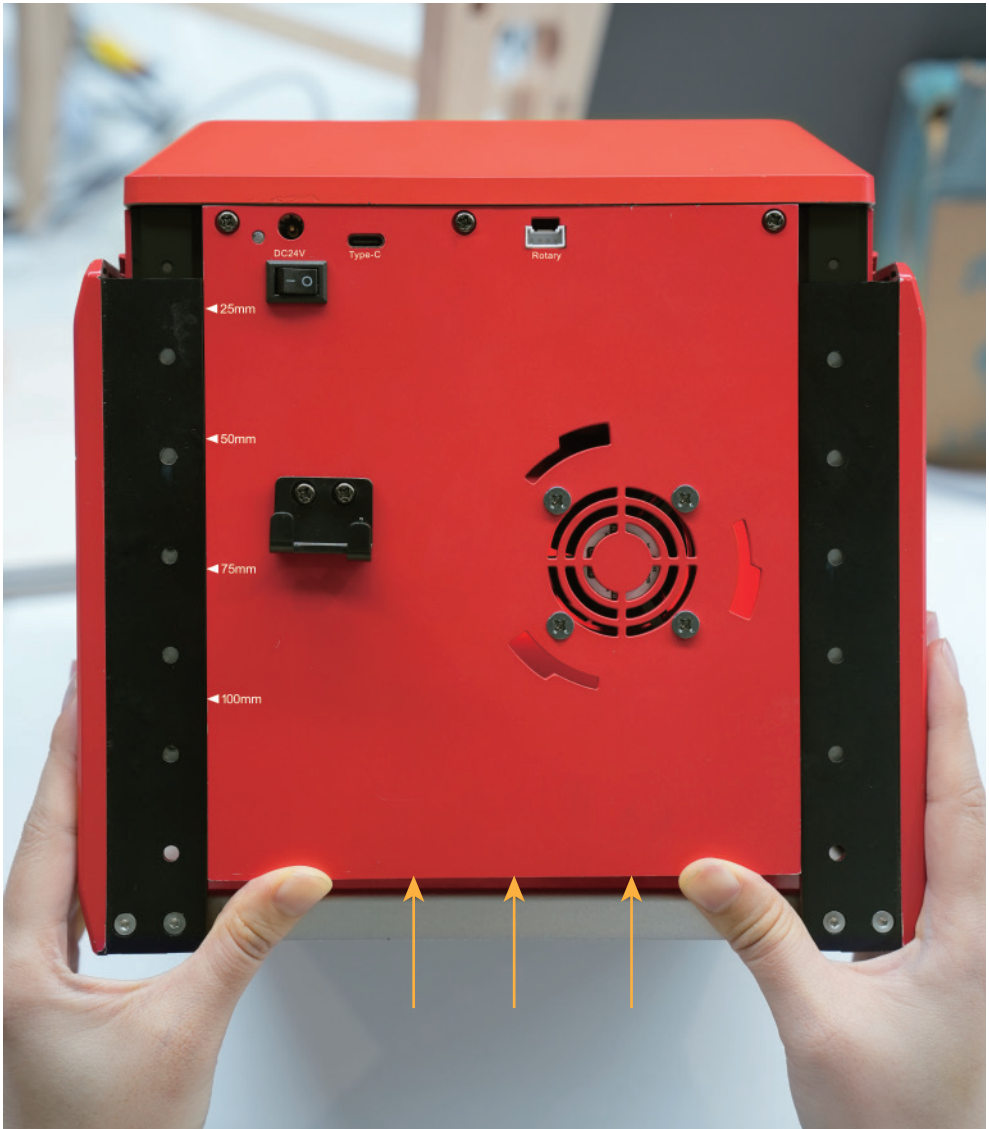

iii. Hold the machine steady with one hand while using the other hand to support the middle of the frame. Lift it upward to the desired position until you hear the locking sound of the limit latch (adjustable heights: 25mm, 50mm, 75mm, 100mm).



25mm



50mm



75mm







100mm

iv. Align the screw holes and tighten the screws to secure.



3.8 Main Port Definition

	Name	Description
 Type-C	Type-C Port	Connect to a computer for file transfer or control, or to a USB drive for file transfer
 DC24V	Power Port	Connect the power supply to power the machine(DC24V)
	Work Control Button	Pause/resume engraving/cutting
	Power Switch	Power ON/OFF the machine ('-' indicates ON, and '0' indicates OFF)
 Rotary	ARR Port	Connect custom ARR accessories

3.9 Operation and Status of the Machine

Status	Operation	Phenomenon	Result
Power on	Switch on the power	The indicator light shows green; screen lights up	The machine powers on and quickly seeks the machine zero point
Power off	Switch off the power	The indicator light turns off; screen turns off	The machine powers off and stops all operations
Pause	Working status, short press the work control button to pause	The work in progress is paused	The work is paused
Resume	Paused status, short press the work control button to resume	The paused work resumes	The work resumes
Screen feedback	Click the screen	A beep sound is emitted when the screen is clicked	The screen provides feedback

3.10 How to Use AlgoOS

The following will explain the use of the AlgoOS system, detailing its functions and usage process.

1. Screen Switch: The AlgoOS system will automatically power on and off with the machine, and the screen will function accordingly.

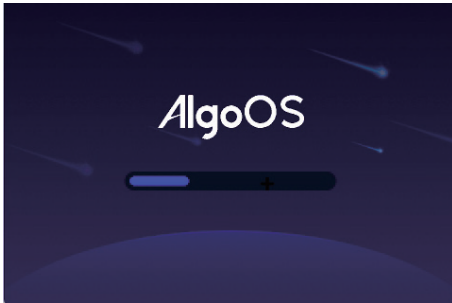

2. Guide for First-time Use:

A. Language Setting: The AlgoOS system supports languages of different regions. Choose your preferred language in the upper right corner to proceed. If you skip this step, you can refer to the user manual to set a new language.

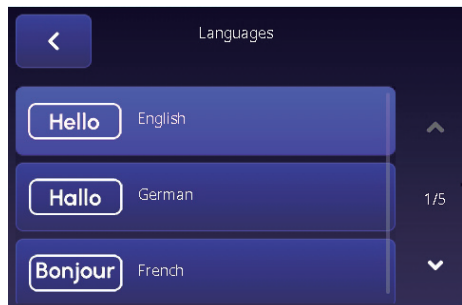

B. Network Connection: The AlgoOS system supports network configuration. You can select and connect to the detected WiFi on the WiFi page. Alternatively, you can click "Skip" to use it directly.

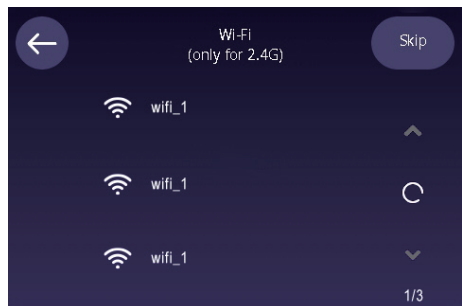
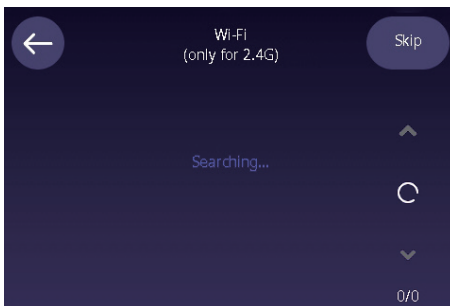

C. Passcode Settings: The AlgoOS system supports screen lock. You can set a passcode now or skip and set it later.

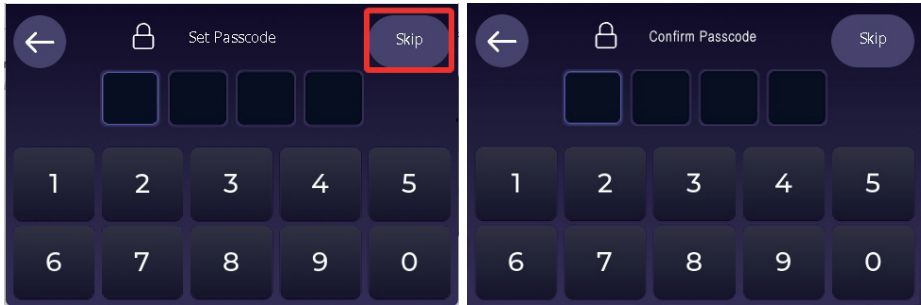

D. Online Help: Scan the code to access the official website, forums, and get assistance.

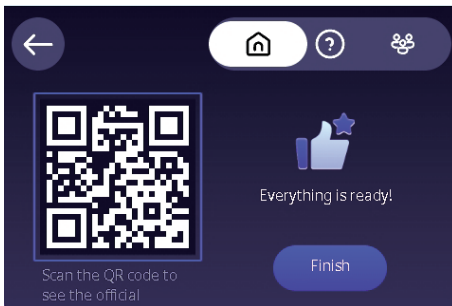

3. Engraving via screen:

A. After powering on the AlgoOS system, select the corresponding laser module (Settings->Machine->Laser), click "Projects" on the home page to enter the "Engraving source" page. Then select the desired engraving file source, which can be either from the SD card, USB or Example. If using USB, make sure to insert the USB drive to access the data.

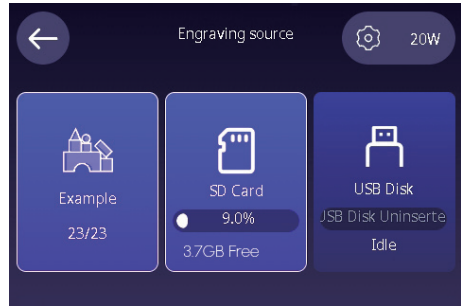

B. After selecting "Example", you'll be directed to the file page, where you can choose the engraving/cutting file.

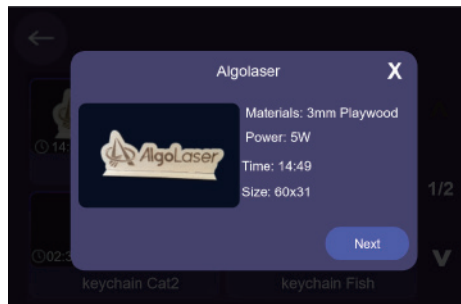
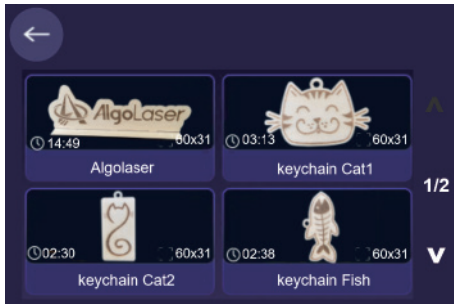

C. Select USB or SD card to enter the file page, select the file for engraving(files should be in image formats such as jpg, png, bmp, svg; or use Gcode document, such as nc, gcode, gc, etc.) After opening the preview page, you can choose to invert colors if needed, then click "Engraving" to proceed to the engraving parameters page.

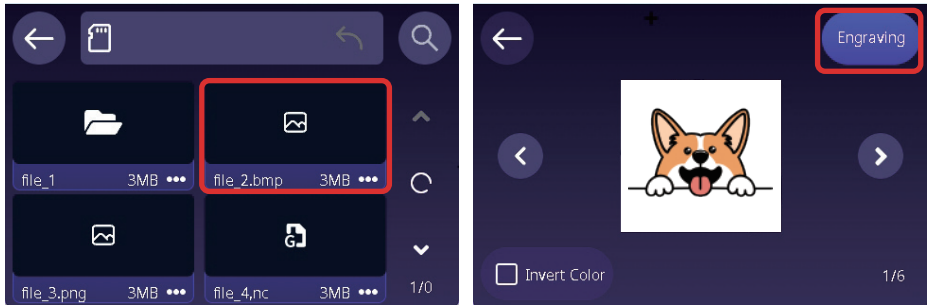

D. On the parameters page, select the engraving/cutting size, quality, power, mode, speed, number of times and other parameters. Once the parameters are confirmed, click on "Processing" to enter the engraving/cutting preparation page.

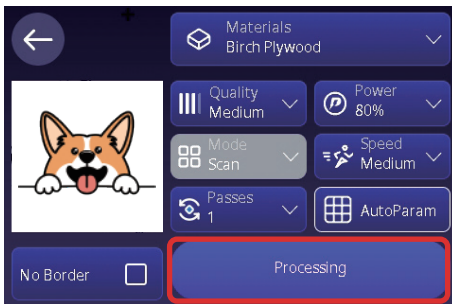

E. Engraving preparation page:

- Focus Verification: ensure that the laser focus focal length is correct, click "Next". And "Not prompt" is selected by default, can be turned on in "Settings--Engraving";

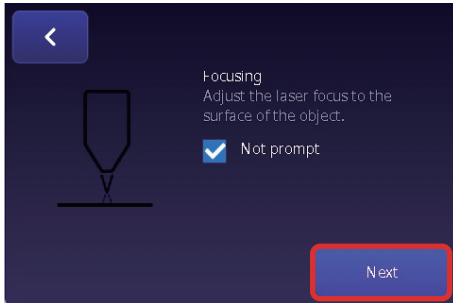

- Engraving area: Adjust the laser position by dragging the image or by clicking "Motion" to move the laser head using the control buttons and use "Step" to adjust the movement distance. Check whether the starting point meets the engraving requirements and ensure the engraving area fully covers the object. Once confirmed, close the protective lid and click "Start" to begin the engraving process.

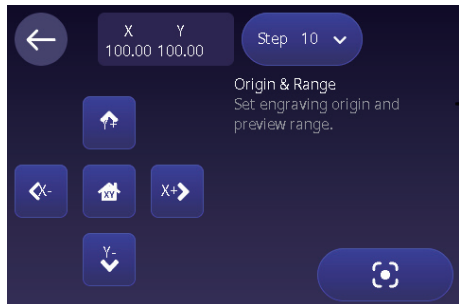
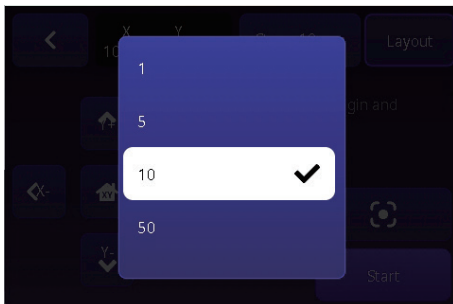
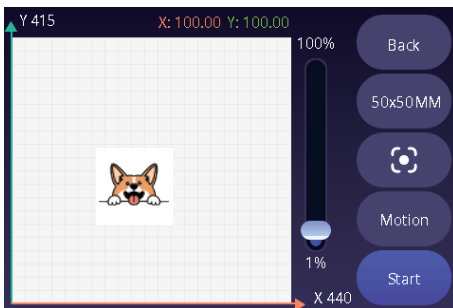

F. Engraving Progress Page: On AlgoOS engraving progress page, you can view the engraving progress, time, parameters, and adjust the engraving speed and laser power in real time. During the engraving process, you can pause/resume by clicking the bottom right button, or end engraving by clicking the bottom left button.

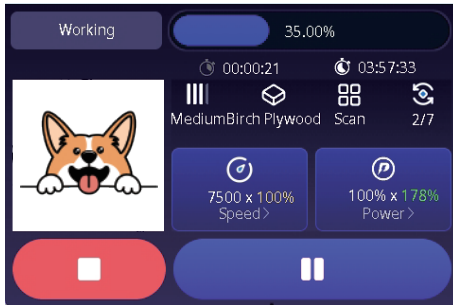

G. Engraving End Page: Upon completion or interruption of engraving, AlgoOS will direct to the engraving end page. "✓" is displayed if the engraving is successful, and "✗" is displayed if it is stopped manually or abnormally. You can click "Again" to retry or "Finished" to back to the file page.

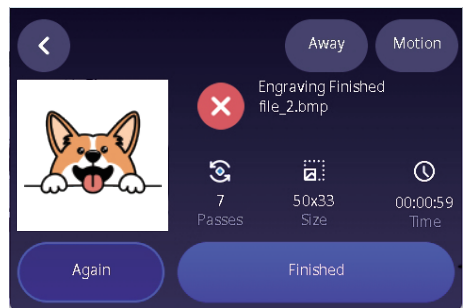
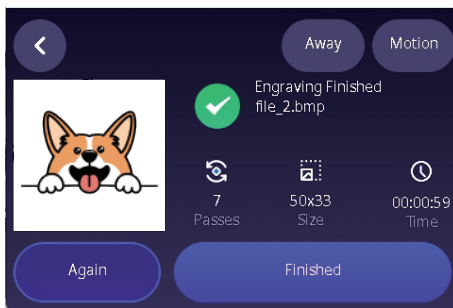

4. Drawing&Writing

On the home page, click the "AlgoSketch" button to enter the drawing & writing page.



- A. Click the pencil, select the appropriate stroke thickness, and use the stylus to start drawing.
- B. Click the eraser, select the appropriate eraser size, and use the stylus to make corrections.
- C. Click the clear button to empty the drawing board.
- D. Click "→" to proceed to the parameters page. The subsequent steps are the same as those for image engraving. Refer to steps F~G of the "Engraving via Screen".

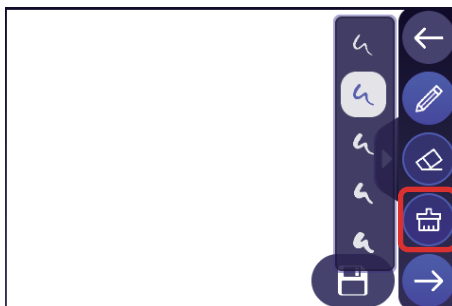
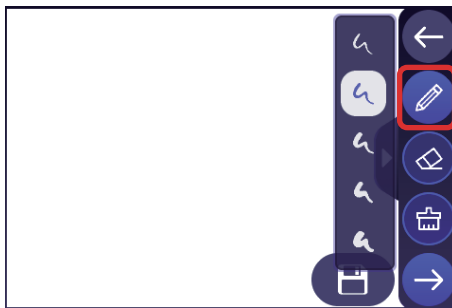

5. Text Engraving:

On the home page, click the "AlgoType" button to enter the text editing page.



A. On the text editing page, double-click the blank area to start typing. Currently, only English text input is supported. Click the "Save" button to save the edited file to the SD card for future engraving. (Note: The file will be saved to the TextEditFile folder.)

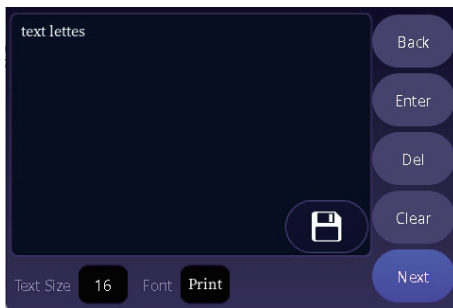

B. The font size can be adjusted to change the text's size; the larger the font size, the clearer the engraving.

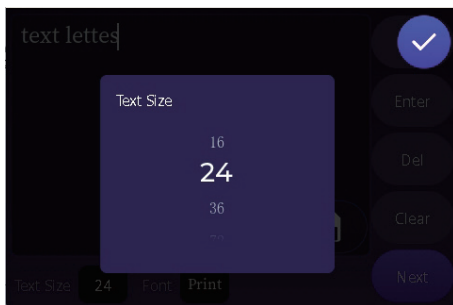

C. The font style can be modified to customize the appearance of the text.

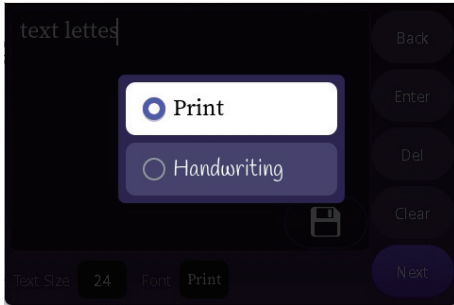

D. Once the input is complete, click "NEXT" to proceed to the parameters page. The subsequent steps are the same as those for image engraving. Refer to steps F~G of the "Engraving via Screen".



6. Screen Lock Setup and Management:

A. Passcode Settings: On the system page(Settings-->System), users can set a passcode and enable or disable the screen lock as needed. Click "Lock Screen" to set/change/enable/disable the screen lock.

Note: Turning off the screen lock will return to the system menu page and clear the current passcode.

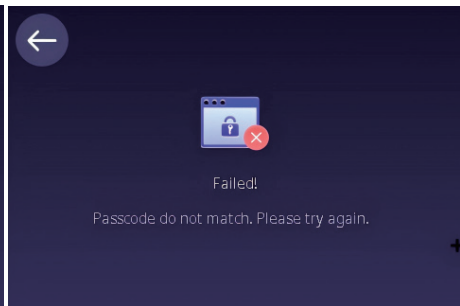
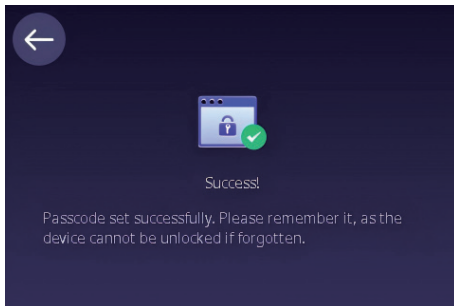
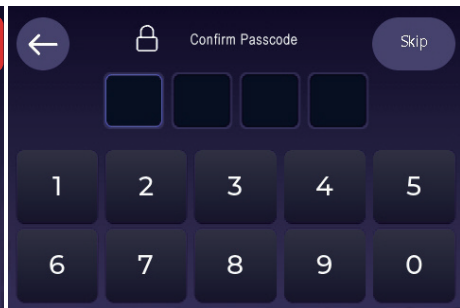
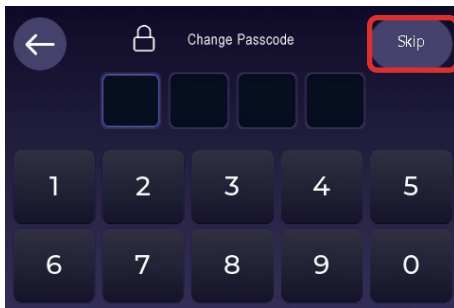
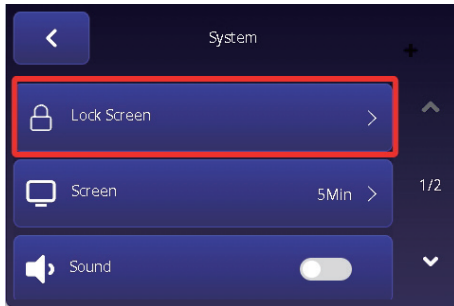

B. Forgot Passcode: If the passcode is forgotten, click "Forgot passcode?" and enter the admin password "9999" to reset/enable/disable the passcode. (Note: The admin password is only for resetting and cannot be used for other purposes.)

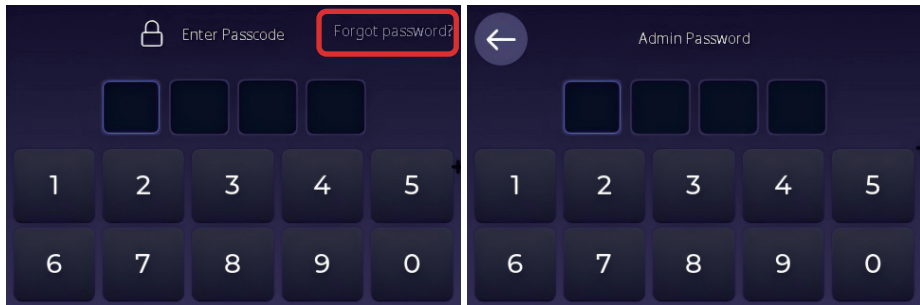

C. Factory Reset: Performing a factory reset will automatically erase the passcode and return the machine to the first startup process.

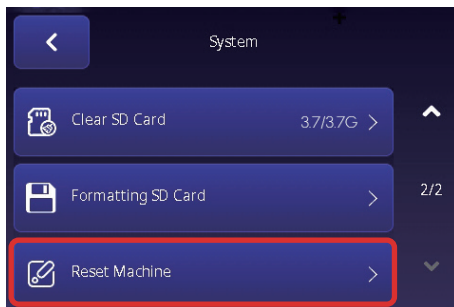

7. Control Modules

The AlgoOS system provides intelligent control of external devices. Click "Control" on the main page to enter the control page.



A. Motion Control Page: With AlgoOS, you can control the machine motion directly, click "Motion" to enter the Motion Control Page. In the middle, use buttons for left shift(X-), right shift(X+), up shift(Y+), down shift(Y-) and homing(XY). Click on the right side, select 1, 5, 10, or 50 to set the distance the machine moves once. Select a speed on the left to adjust the speed of the machine. To halt the machine's movement, click the red button on the upper right corner.



8. Settings Module

The AlgoOS settings module contains machine settings and system settings.

A. USB File Transfer: The machine is equipped with a built-in SD card. Open the USB File Transfer, and use a Type-C cable to connect the machine to your computer. You can then manage the files on the SD card disk directly from your computer.

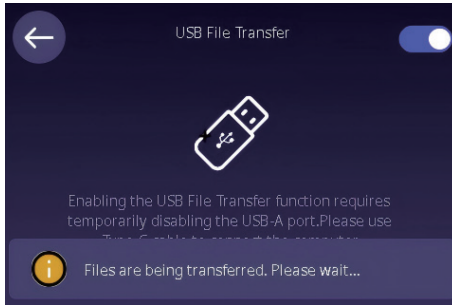
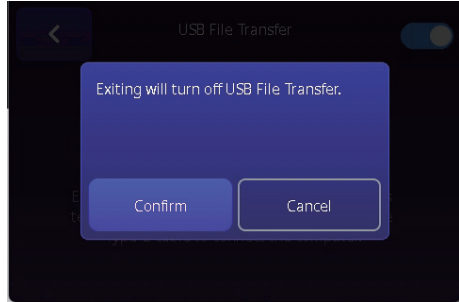
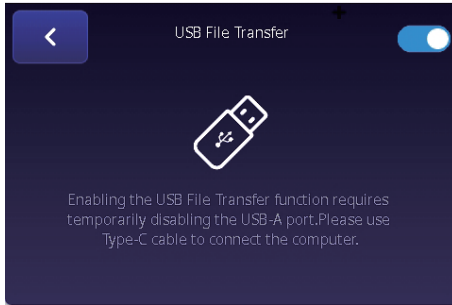

B. Machine

i. Working Mode:

There are three working modes in the AlgoOS system that is XYZ Plane Mode, ARR Roller Mode and ARC Chuck Mode.

XYZ Plane Mode: Supports engraving in the XY plane;

ARR Roller Mode: Supports rolling engraving with external accessory Rotary Roller;

ARC Chuck Mode: Supports gripping and engraving with external ARC Chuck jaws.

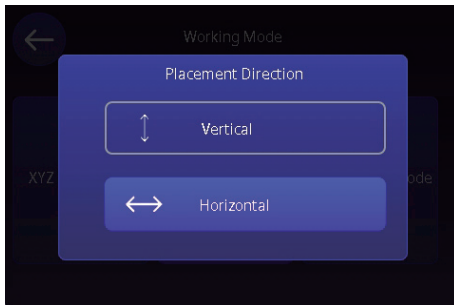
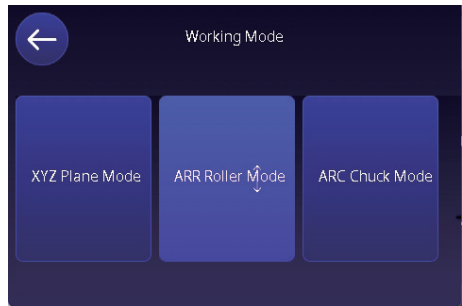
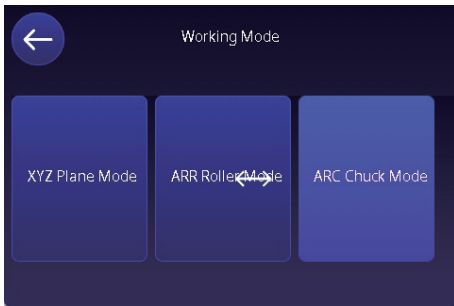
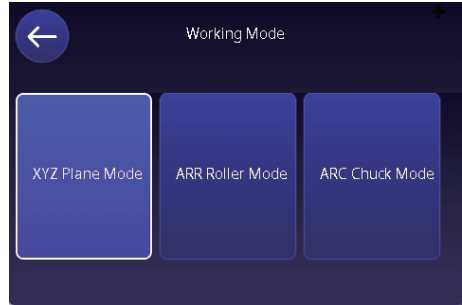
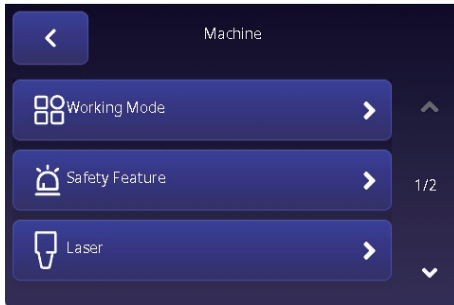

ii.Safety Feature:

Sensitivity Setting: Set AlgoOS to detect vibration offset sensitivity. Slide the slider to set the sensitivity value, the smaller the value, the higher the sensitivity. Click the upper right button to restore the default value.

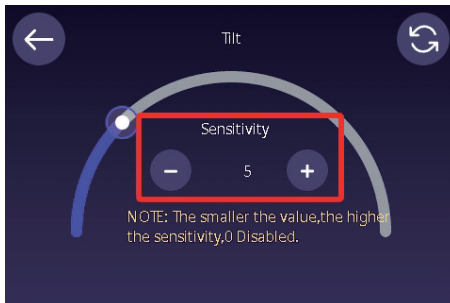
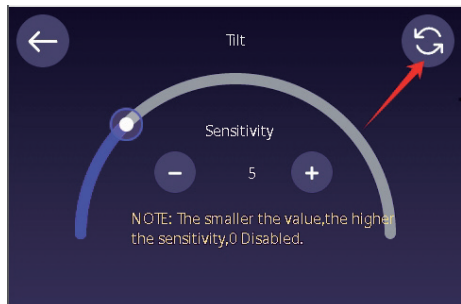
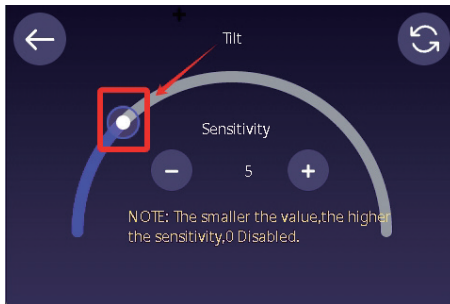
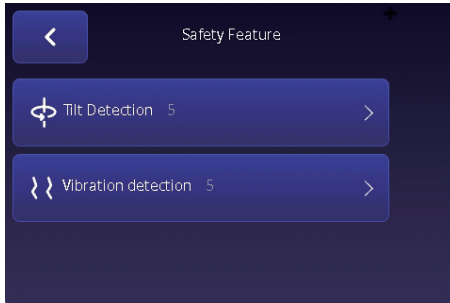

iii. Laser

Select a laser module if needed.



iv. Motion Mode: Motion modes include High Precision, Balance, High Efficiency.

Select "High Precision": Slow acceleration to significantly reduce shaking and vibration during engraving, but with a longer engraving time.

Select "Balance": Moderate acceleration to slightly reduce shaking and vibration during engraving, with a slightly longer engraving time.

Select "High Efficiency": Maximum acceleration, which may result in some shaking and vibration during engraving, but significantly reduces the engraving time.

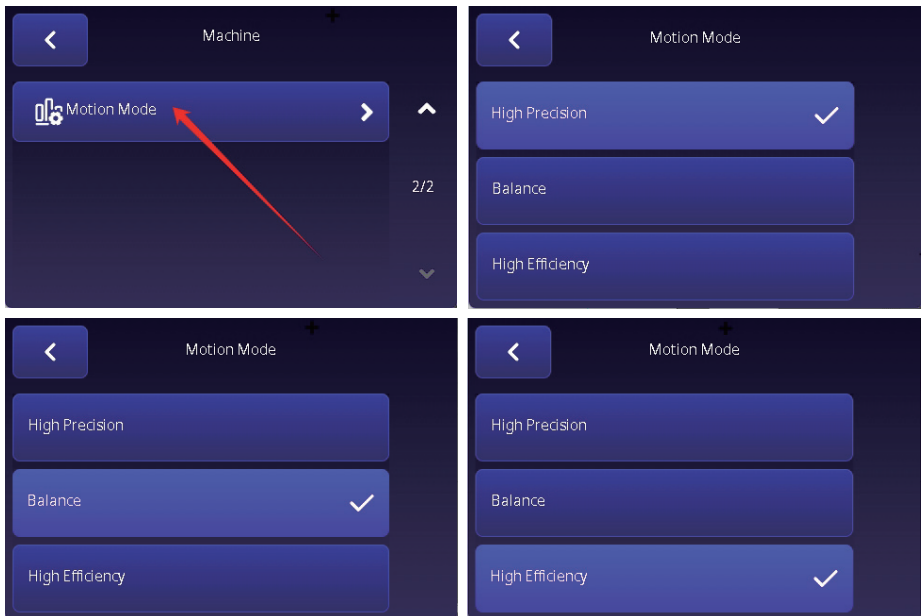

C. Interrupt Recovery:

The AlgoOS system provides the function of recovery engraving when the machine is interrupted. The motor will remain locked once the interrupt function is turned on. The interrupted file information is recorded, click "Confirm" to resume engraving or click "Cancel" to cancel.

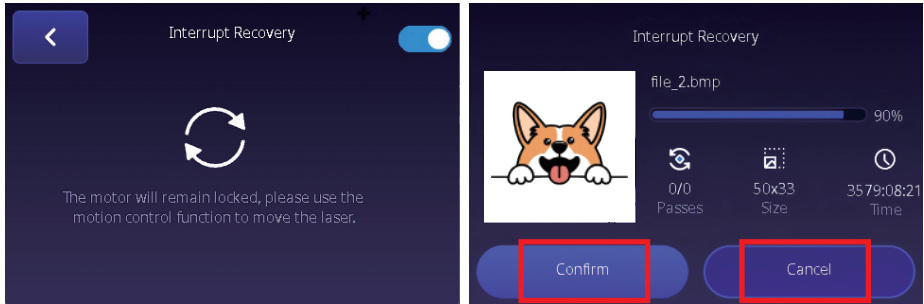

D. System Menu:

The AlgoOS system settings can be changed in the system menu. The system menu includes Working Mode, Screen, Sound, Clean SD Card, Formatting SD Card, and Reset Machine.

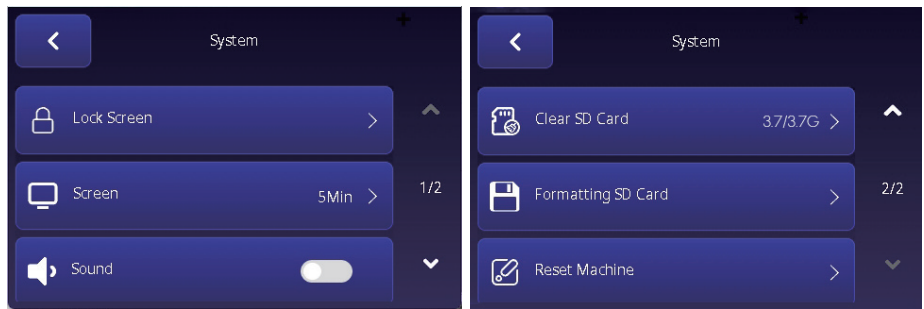

i. Screen: Click "1Min", "5Min", "30Min", "Never" to set the rest time, or click "-", "+" button to set the rest time precisely. The screen will sleeping according to the set time after no operation.

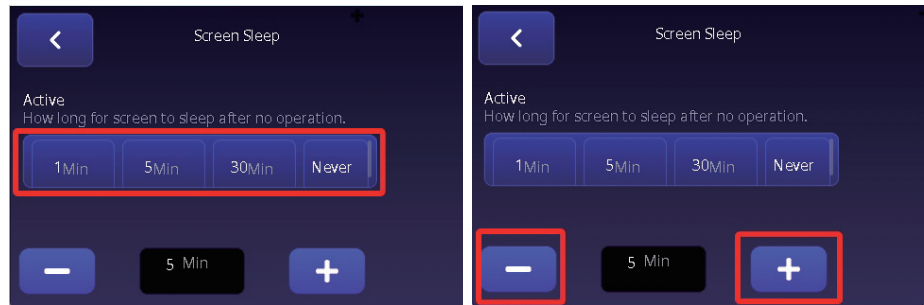

ii. Sound: When working with the AlgoOS system, tapping on the screen will follow a sound effect. You can switch the sound effect on or off by clicking the switch.

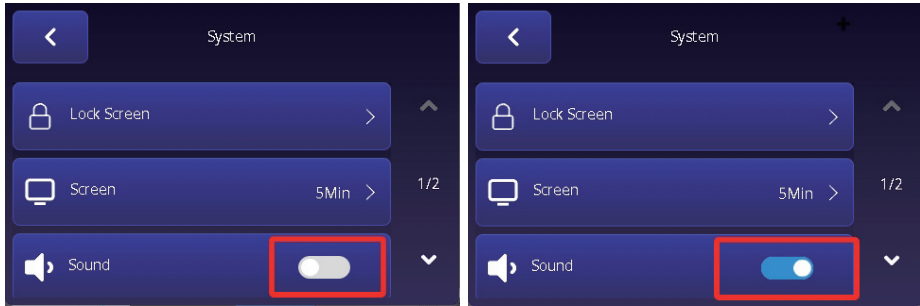

iii. Clean SD Card: Click "Clear" to clean the SD card, cleaning the SD card will empty all the files in the SD card.

iv. Formatting SD Card: Click "Formatting" to format the SD card, the SD card will be emptied and the built-in AlgoOS files will be deleted. After formatting, you can download the related files from the algolaser.com website

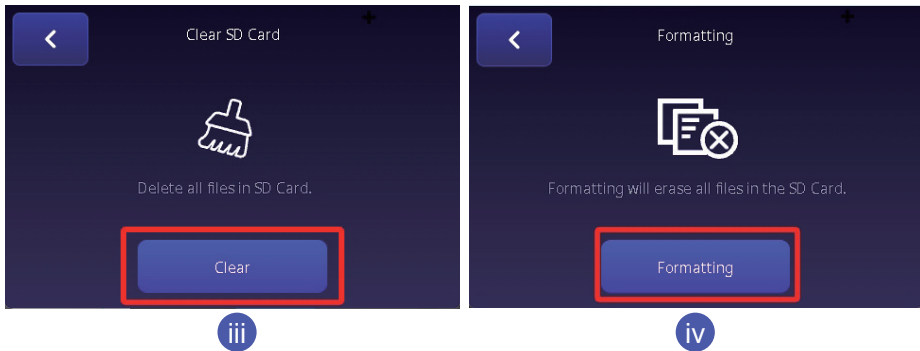

v. Reset: Click "Reset Machine" to reset the AlgoOS system and all settings will be reset to default.

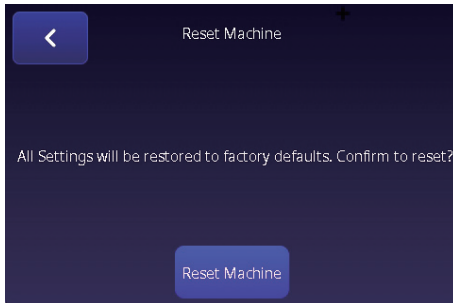

E. Device self-test: AlgoOS provides a set of process to test the device:

Step 1: Detect whether the laser can emit light normally;

Step 2: Detect whether the screen color is displayed normally and whether there is any damage to the screen display;

Step 3: Check whether AlgoOS can detect machine vibration;

Step 4: Check whether the built-in SD card can be used normally and whether the built-in font file exists;

The system will provide the test results after detection, and you can click to find the failure tips for the detected failure steps.

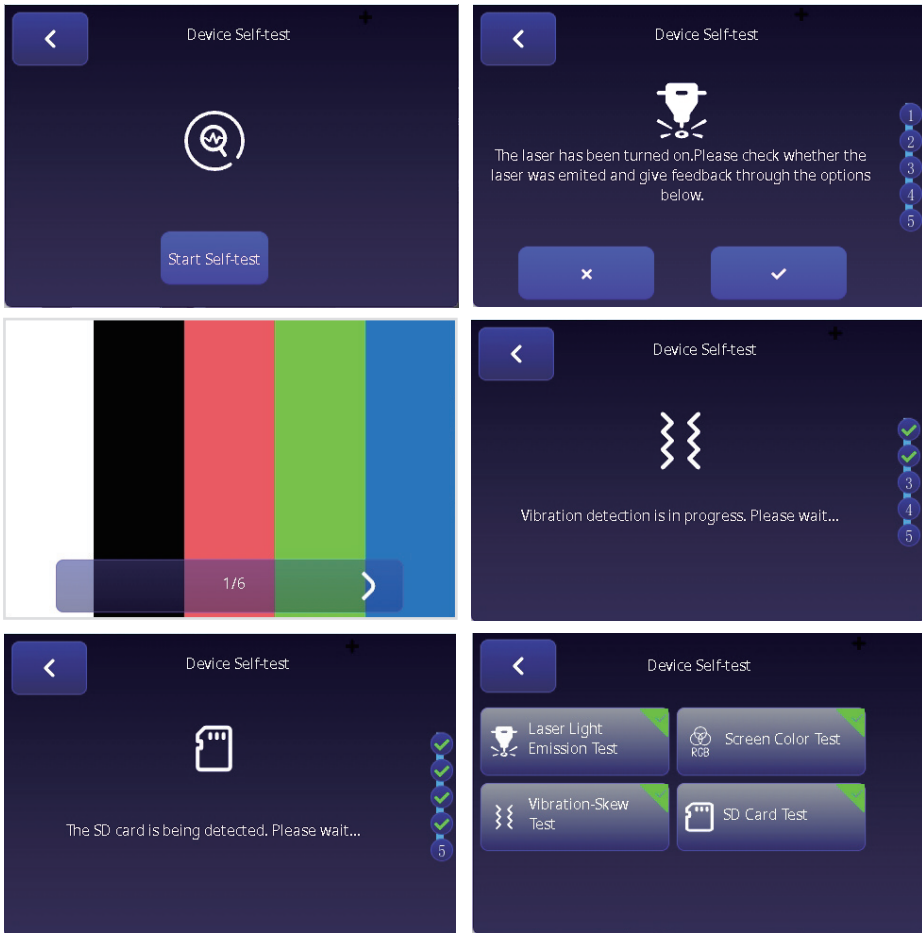

F. Update Firmware: AlgoOS provides system upgrade, which will update the latest features and optimize the experience occasionally. Enter the update page and wait for the system to detect a new version. When the new version is detected, click "Click to update" to start the update. After the updated successfully, the system will reboot in 5S, then the update is completed.

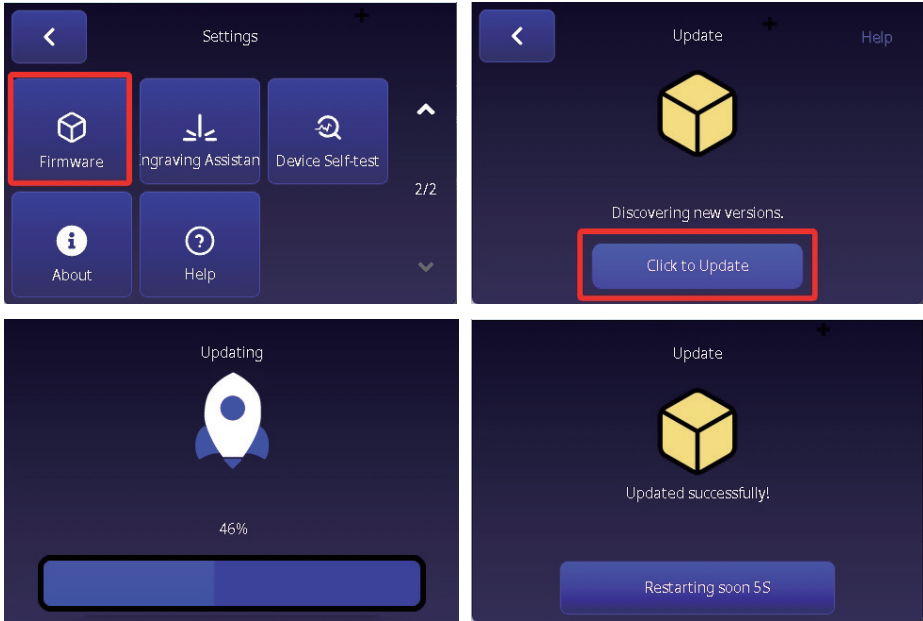

G. Engraving Assistant: You can set whether or not a focused laser needs to be prompted during the engraving process, and set the origin position as well as the engraving range.

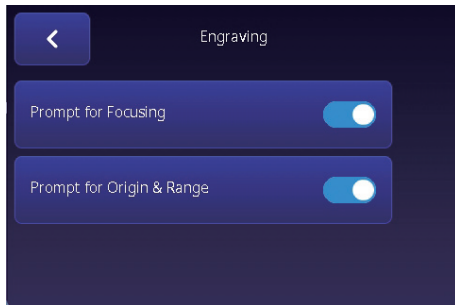

H. About: On the About page, you can check the firmware version of the AlgoOS, machine model, hardware version, and WIFI Address.

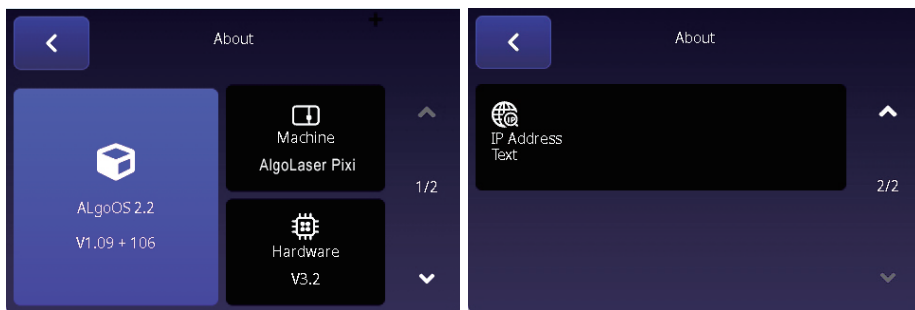

I. Help Page: Scan the QR code to access the official website, view FAQs or join the discussion.

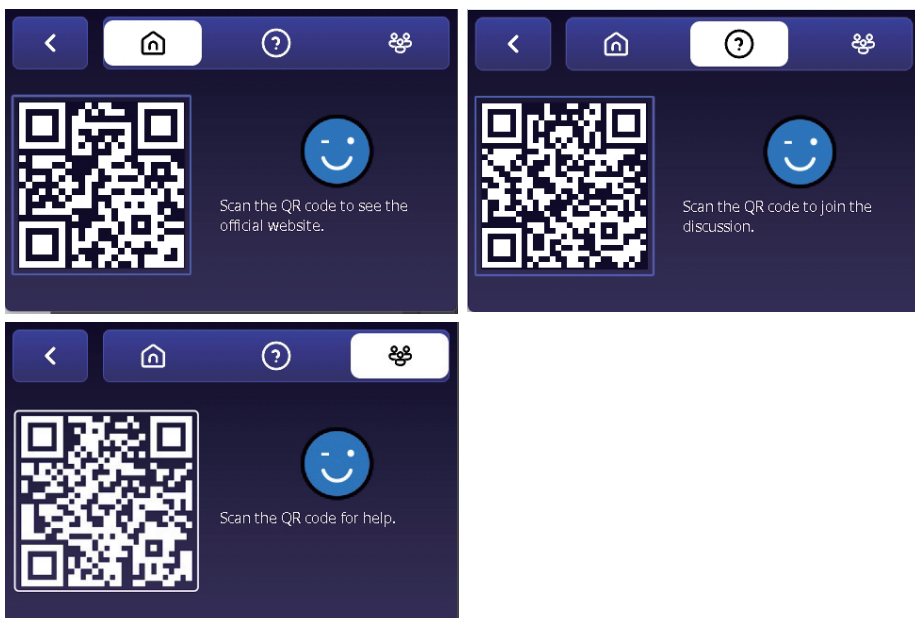

3.11 How to Connect Pixi to APP via WiFi

Download the app (use your phone to scan the QR code below to download and install the app; or search for the app name "AlgoLaser" in the mobile app store.)



Google Play



App Store

- ① Before using the app to control the machine in distribution mode, connect your phone to the 2.4Ghz band Wi-Fi network.
- ② Open Algotlaser's mobile app and go to the app homepage.

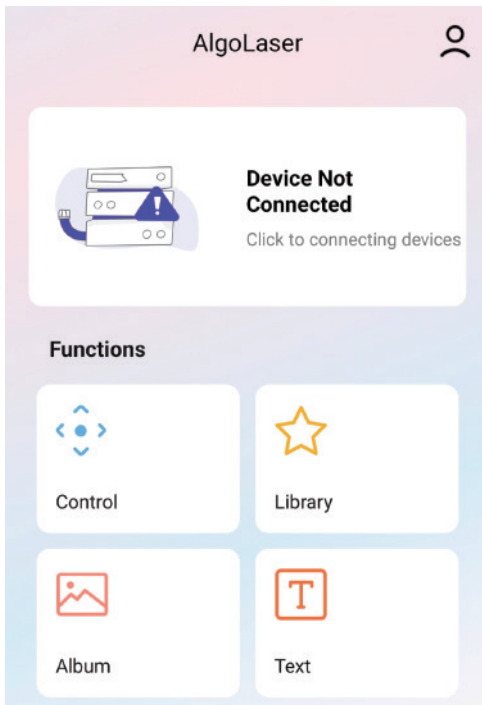

- ③ Choose Pixi , Click “Beginner's course”
- ④ Follow AlgoLaser Pixi.App distribution process

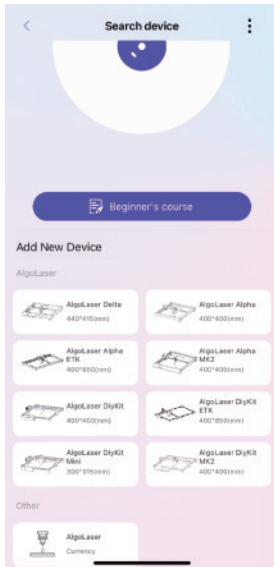

- ⑤ Machine displays network available. Click “Beginner's course” to proceed.

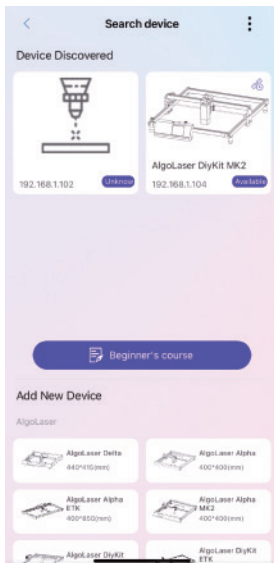

- ⑥ After a successful connection, the app will redirect to the home page with relevant machine information.

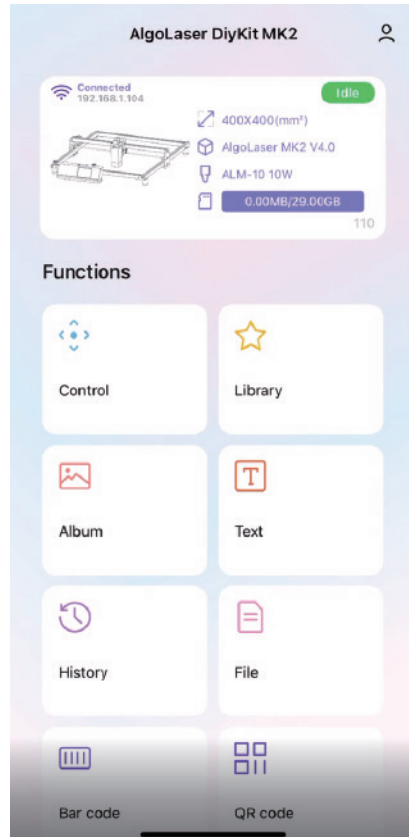
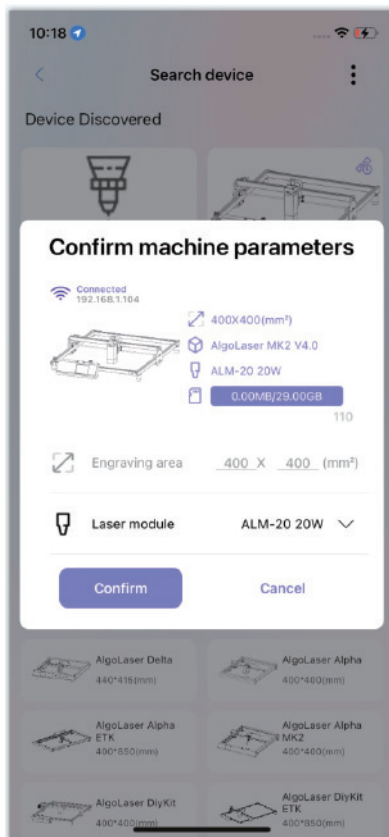

- ⑦ Let's import an image to try a full engraving.
- ⑧ Click the "Library" to access the app's Library page. Select the pattern that you want to engrave.
- ⑨ Enter the picture editing page, first-time users, directly skip and click "NEXT" for the next step.
- ⑩ After accessing this page, adjust the image size for engraving. Select the boxed button in the figure and allow the machine to move slightly, determining the appropriate image size and location of the engraving trajectory.
- ⑪ Click "Configure" to access the configuration page.

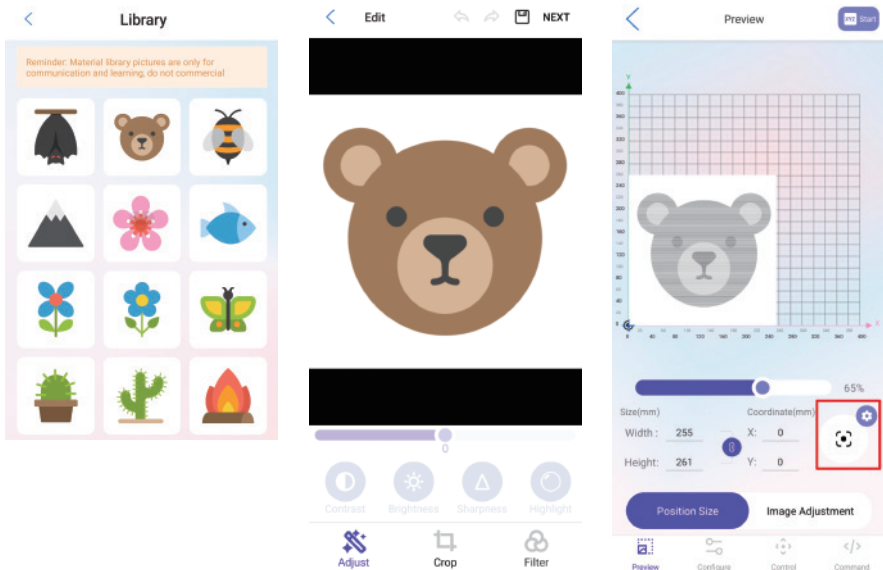

- 12 Set the parameters for engraving on the “Configure” page. There are plenty of pre-set parameters available for the AlgoLaser. Simply locate the appropriate preset and click to select it.
 - a. “3W” boxed in red.
 - a) Indicates a 3W laser module.
 - b. “Scans”, “basswood” boxed in red.
 - a) For engraving, choose the “Scans” mode.
 - b) “Basswood”, choose the appropriate wood based on the specific situation, whether it be basswood or other suitable options.

(Note: If there is a discrepancy between the engraving parameters and the desired effect, adjust the parameters accordingly.)
- 13 Click “Start” in the upper right corner to proceed. Check if the laser module is focused. If not, refer to the manual for instructions on focusing. If already in focus, click “Checked” to the next step.
- 14 Prompt for selecting the starting point of the laser module engraving: click “Start” to the next step for the first time.

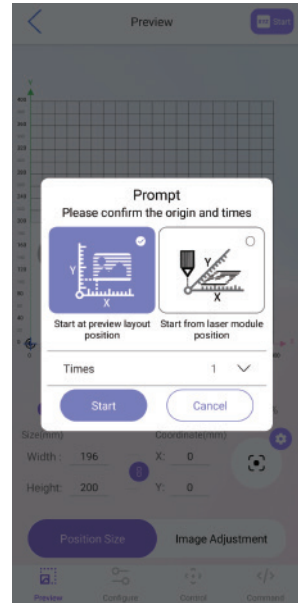
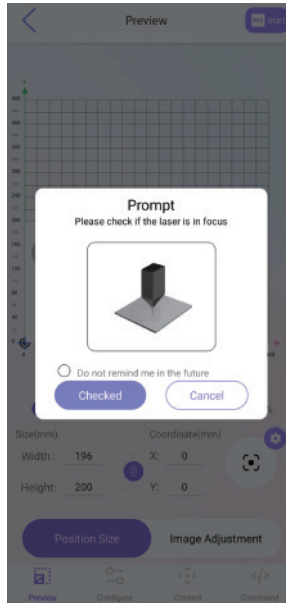
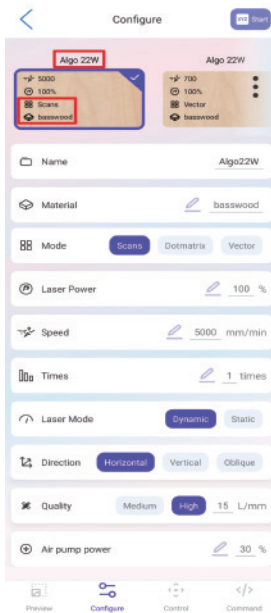

- ⑮ Wait for the image conversion to finish.
- ⑯ Click the "Run" button to start engraving.

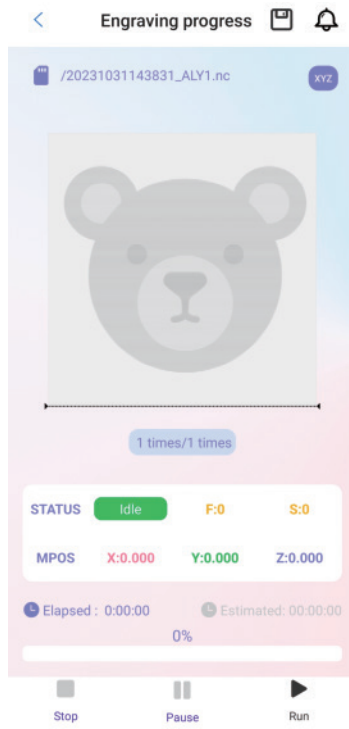
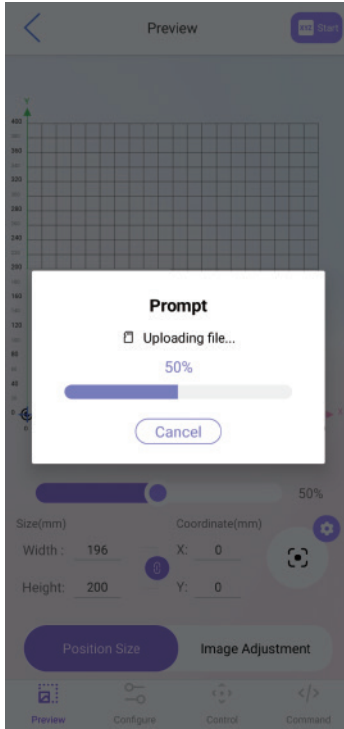

3.12 How to Connect the Machine to a PC

- Install the driver: Before installing the computer driver, please power on the machine and connect it to the PC using a USB cable. Then, choose the appropriate driver file based on your computer system and proceed with the installation.

Operating System	Operation	Phenomenon
WIN 7/WIN 8	 zadig-2.8.exe	<p>To install the driver, make sure the machine is powered on and connected to the computer via USB.</p> <p>The installation process can only be carried out when the machine is in the powered-on state and connected to the computer.</p>
WIN 10/WIN 11	No installation required	
Mac	No installation required	

- To check the driver installation, follow these steps:
 - ① Find the Device Manager on your computer.
 - ② Navigate to the Ports section.
 - ③ Disconnect the USB cable from the computer.
 - ④ Observe that the new serial port disappears from the Ports section.
 - ⑤ Reconnect the USB cable.
 - ⑥ Verify that a new serial port appears, indicating successful driver installation.

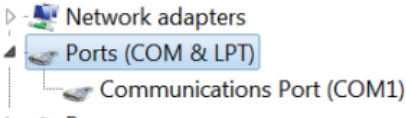

- Connecting the machine
 - ① Launch the LaserGRBL / LightBurn software.



Note: The LightBurn software requires a purchase to use.

- ② Select the COM port that corresponds to the one identified in step two of the installation process.
- ③ Click on the “Connect” button.
- ④ If a welcome message appears in the command box, it indicates a successful connection.

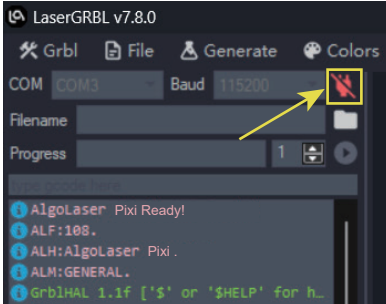
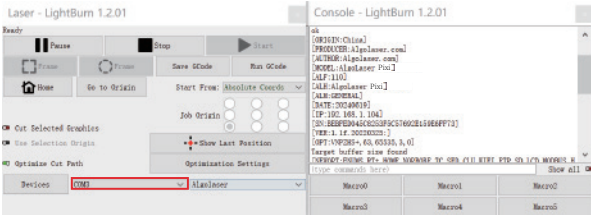

Note:

If you use Lightburn for the first time, in order to operate logic with the AlgoLaser machine, be sure to choose the following two positions as the lower left corner.

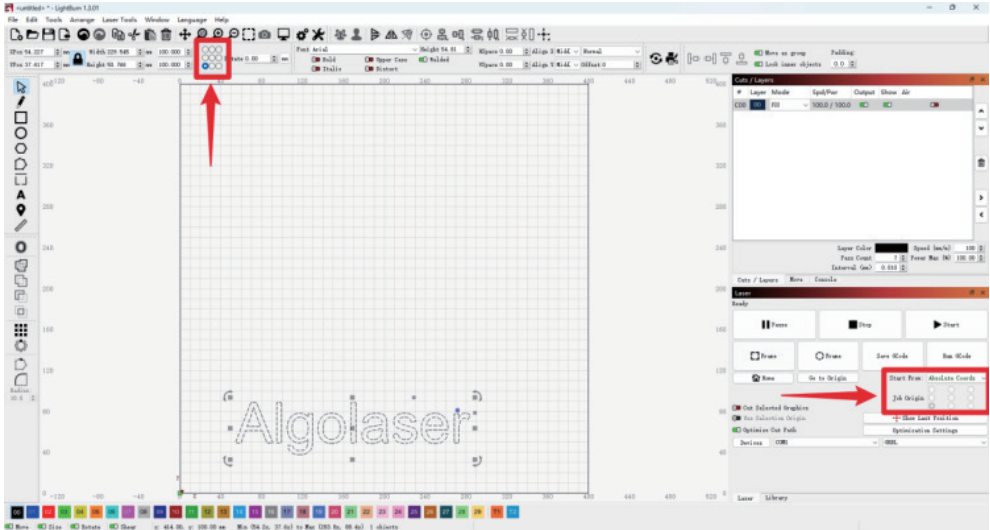

Win7 & Win8 Driver Installation Tutorial

Resolution for Driver issues on ESP MCU Express if CDC Device Error

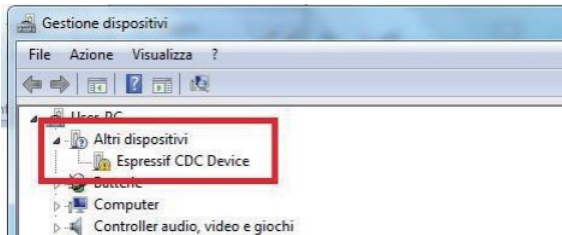

- Or the corresponding driver cannot be detected

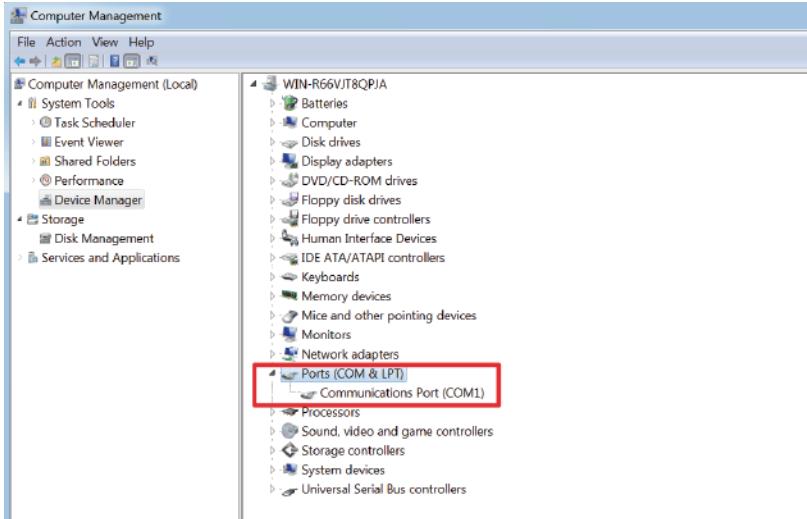

- Visit <https://zadig.akeo.ie/>
 Navigate lower on the page and click The download button

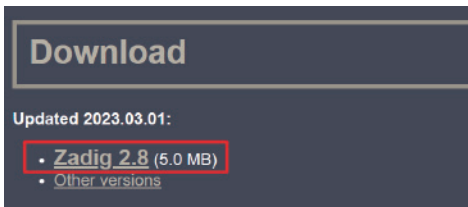

- Once open select List All Devices from the menu Options.

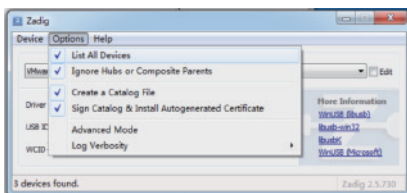

Wait for the refresh

- Select AlgoLaser X CDC Device (Interface 0) from the drop-down list.

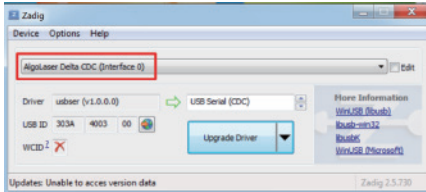

- Select USB Serial (CDC) from the list of drivers available, click the Install Driver button, and wait for the installation to complete.

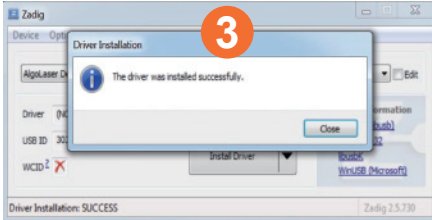
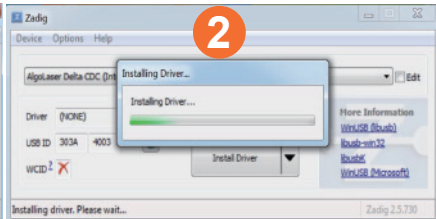
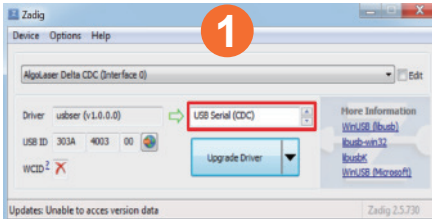

- When you finished it, you can close the Zadig software
- The New AlgoLaser X CDC (Interface 0) (COMX) port in Device Manager. Note the COM number might be different in your machine

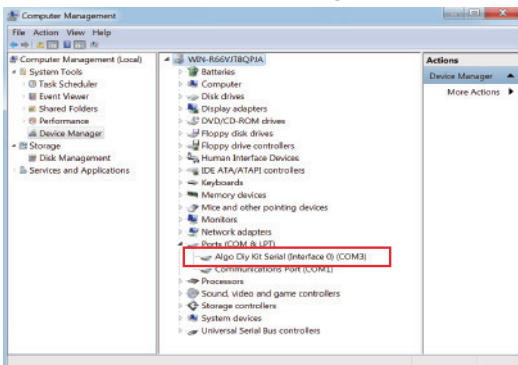

FAQ

Installation and Startup Issues

- **Issue 1:** Pixi cannot power on or the screen does not respond

Possible Causes:

- Power is not connected.
- Plug is loose.
- Adapter is damaged.

Solutions:

- Check if the power connection is stable and ensure you are using the official adapter.
- Verify that the power outlet is functioning and try a different outlet.
- If the power supply is normal but the device still won't turn on, contact technical support.

Software and Connection Issues

- **Issue 1:** Machine cannot connect to WiFi

Possible Causes:

- Unstable WiFi signal.
- Frequency not supported(Machine only supports 2.4G frequency).
- Incorrect WiFi password.

Solutions:

- Ensure the machine is connected to a 2.4G frequency WiFi network and check the signal strength.
- Confirm that the WiFi password is entered correctly (case-sensitive).
- Restart the machine and the router, then reconnect.

- **Issue 2:** The computer software cannot connect to the machine

Possible Causes:

- Incorrect port selection.
- The computer is running Windows 7 or Windows 8.

Solutions:

- Try switching COM ports to establish a connection.
- If the computer is running Windows 7 or Windows 8, download the appropriate drivers.
- For details, refer to section 3.10 of the manual: "How to Connect the Machine to a PC."

Engraving and Cutting Quality Issues

- **Issue 1:** Engraved patterns are misaligned or shifted

Possible Causes:

- Material is not secured.
- Machine vibration.
- Improper engraving parameters.

Solutions:

- Use clamps or tape to secure the material, ensuring it doesn't move during engraving.
- Place the machine on a stable surface to avoid external vibrations.
- Adjust speed and acceleration parameters to reduce shifting caused by excessive motion.

- **Issue 2:** Engraving is unclear or lacks intensity

Possible Causes:

- Focus is not adjusted.
- Unsuitable material selection.
- Incorrect power or speed settings.

Solutions:

- Use a focusing tool to adjust the laser module's focus, ensuring the laser spot is minimized.
- Verify that the material is suitable for laser engraving and adjust power, speed, and other parameters.
- Clean the laser lens to ensure there is no dust or debris obstructing the laser output.

- **Issue 3:** Cutting is incomplete or edges are burned

Possible Causes:

- Insufficient power.
- Excessive cutting speed.
- Material thickness exceeds the laser's capability.

Solutions:

- Increase laser power or reduce cutting speed to allow sufficient time for the laser to cut through.
- Check if the material thickness exceeds the laser cutting capacity.

- **Issue 4:** Lens or laser module is damaged

Possible Causes:

- Lens not cleaned for a long time.
- External impact.

Solutions:

- Regularly clean the lens with an alcohol swab (recommended every 20 hours of cumulative use) to avoid dust buildup that affects laser output.
- Replace the lens assembly if it is damaged.

Safety Issues

- **Issue 1:** Tilt detection triggers frequently

Possible Causes:

- Device is not placed on a stable surface.
- Internal sensor malfunction.

Solutions:

- Ensure the device is placed on a flat surface or adjust the tilt detection sensitivity.
- If frequent tilt detection occurs without noticeable tilting, contact after-sales support to inspect the sensor.

Certificate



Certificate of Conformity

Certificate Number: DL-250207002EC

Applicant: Shenzhen Algo Technologies Co., Ltd.
5th Floor, Building E5, Juyin Technology Industrial Park, Garli Road, Longgang District, Shenzhen 518116, China

Manufacturer: Shenzhen Algo Technologies Co., Ltd.
5th Floor, Building E5, Juyin Technology Industrial Park, Garli Road, Longgang District, Shenzhen 518116, China

Product: Laser Engraver

Trade Mark: AlgoLaser

Model No.: Pixi
Zeta, Lumo, Pixi Lite, Lumo Lite, Alpha MK3, Delta MK3, Pixi MK2, Pixi Pro, Pixi2.0, Pixi Max, Pixi Lite MK2, Pixi Pro2.0, Pixi Lite2.0, Gamma

Essential requirement	Applied Standards	Report Number
Art.3.1(a) Health	EN IEC 62311:2020, EN 50665:2017	DL-250207002-1ER
Art.3.1(b) EMC	ETSI EN 301 488-1 V2.2.3 (2019-11), ETSI EN 301 488-17 V3.3.1 (2024-09)	DL-250207002-2ER
Art.3.2 Radio	ETSI EN 300 328 V2.2.2 (2019-07)	DL-250207002-3ER
Art.3.1(a) Safety	EN IEC 62368-1:2024+A11:2024	DL-250207002SR

The EUT described above has been tested by us with the listed standards and found in compliance with the council Radio Equipment Directive (RED) 2014/53/EU. It is possible to use CE marking to demonstrate the compliance with this RED Directive. It is only valid in connection with the test report number as listed.



This certificate of conformity is based on a single evaluation of the submitted sample(s) of the above mentioned product. It does not imply an assessment of the whole product and release. Without the written approval, it is not permitted to use the test lab's logo.

Shenzhen DL Testing Technology Co., Ltd.
101-201, Competition Building, Tengzhou Electronics Longgang Factory Area, No.1 Baokang Fifth Road, Baokang Community, Baokang Street, Longgang District, Shenzhen, China
Web: www.dl-test.com E-mail: Service@dl-test.com Tel: 400-688-3532





Certificate of Conformity

Certificate Number: DL-250207004RC-1

Applicant: Shenzhen Algo Technologies Co., Ltd.
5th Floor, Building E5, Juyin Technology Industrial Park, Garli Road, Longgang District, Shenzhen 518116, China

Manufacturer: Shenzhen Algo Technologies Co., Ltd.
5th Floor, Building E5, Juyin Technology Industrial Park, Garli Road, Longgang District, Shenzhen 518116, China

Product: Laser Engraver

Trade Mark: AlgoLaser

Model No.: Pixi
Zeta, Lumo, Pixi Lite, Lumo Lite, Alpha MK3, Delta MK3, Pixi MK2, Pixi Pro, Pixi2.0, Pixi Max, Pixi Lite MK2, Pixi Pro2.0, Pixi Lite2.0, Gamma

Test Standard: IEC 62321-1:2019; IEC 62321-2:2019; IEC 62321-3-1:2019;
IEC 62321-4:2019+A1:2017; IEC 62321-6:2013; IEC 62321-6:2019;
IEC 62321-7-1:2019; IEC 62321-7-2:2017; IEC 62321-8:2017

The EUT described above has been consolidated by us and found in compliance with the council RoHS Directive (EU) 2015/863 amending Annex II to Directive 2011/65/EU. The certificate applies to the tested sample above mentioned only and shall not imply an assessment of the whole production. It is only valid in connection with the test report number: DL-250207004RR-1.



This certificate of conformity is based on a single evaluation of the submitted sample(s) of the above mentioned product. It does not imply an assessment of the whole product and release. Without the written approval, it is not permitted to use the test lab's logo.

Shenzhen DL Testing Technology Co., Ltd.
101-201, Competition Building, Tengzhou Electronics Longgang Factory Area, No.1 Baokang Fifth Road, Baokang Community, Baokang Street, Longgang District, Shenzhen, China
Web: www.dl-test.com E-mail: Service@dl-test.com Tel: 400-688-3532





Certificate of Conformity

Certificate Number: DL-250207003EC

Applicant: Shenzhen Algo Technologies Co., Ltd.
5th Floor, Building E5, Juyin Technology Industrial Park, Garli Road, Longgang District, Shenzhen 518116, China

Manufacturer: Shenzhen Algo Technologies Co., Ltd.
5th Floor, Building E5, Juyin Technology Industrial Park, Garli Road, Longgang District, Shenzhen 518116, China

Product: Laser Engraver

Trade Mark: AlgoLaser

Model No.: Pixi
Zeta, Lumo, Pixi Lite, Lumo Lite, Alpha MK3, Delta MK3, Pixi MK2, Pixi Pro, Pixi2.0, Pixi Max, Pixi Lite MK2, Pixi Pro2.0, Pixi Lite2.0, Gamma

Essential requirement	Applied Standards	Report Number
Art.3.1(a) Health	BS EN IEC 62311:2020, BS EN 50665:2017	DL-250207003-1ER
Art.3.1(b) EMC	ETSI EN 301 488-1 V2.2.3 (2019-11) ETSI EN 301 488-17 V3.3.1 (2024-09)	DL-250207003-2ER
Art.3.2 Radio	ETSI EN 300 328 V2.2.2 (2019-07)	DL-250207003-3ER
Art.3.1(a) Safety	BS EN IEC 62368-1:2024+A11:2024	DL-250207002SR

The EUT described above has been tested by us with the listed standards and found in compliance with the EMC directive 51:2017 No.12020. It is possible to use UKCA marking to demonstrate the compliance with this EMC directive. It is only valid in connection with the test report number as listed.



This certificate of conformity is based on a single evaluation of the submitted sample(s) of the above mentioned product. It does not imply an assessment of the whole product and release. Without the written approval, it is not permitted to use the test lab's logo.

Shenzhen DL Testing Technology Co., Ltd.
101-201, Competition Building, Tengzhou Electronics Longgang Factory Area, No.1 Baokang Fifth Road, Baokang Community, Baokang Street, Longgang District, Shenzhen, China
Web: www.dl-test.com E-mail: Service@dl-test.com Tel: 400-688-3532



FCC Compliance Statements

This device complies with Part 15 of the FCC Rules. Operation is subject to the following two conditions: (1) this device may not cause harmful interference, and (2) this device must accept any interference received, including interference that may cause undesired operation.

Caution: Changes or modifications not expressly approved by the party responsible for compliance could void the user's authority to operate the equipment.

Note: This equipment has been tested and found to comply with the limits for a Class B digital device, pursuant to Part 15 of the FCC Rules. These limits are designed to provide reasonable protection against harmful interference in a residential installation. This equipment generates, uses and can radiate radio frequency energy and, if not installed and used in accordance with the instructions, may cause harmful interference to radio communications. However, there is no guarantee that interference will not occur in a particular installation.

If this equipment does cause harmful interference to radio or television reception, which can be determined by turning the equipment off and on, the user is encouraged to try to correct the interference by one or more of the following measures:

- Reorient or relocate the receiving antenna.
- Increase the separation between the equipment and receiver.
- Connect the equipment into an outlet on a circuit different from that to which the receiver is connected.
- Consult the dealer or an experienced radio/TV technician for help.

ISED Compliance Statements

This device contains licence-exempt transmitter(s)/receiver(s) that comply with Innovation, Science and Economic Development Canada's licence-exempt RSS(s). Operation is subject to the following two conditions:

- (1) This device may not cause interference.
- (2) This device must accept any interference, including interference that may cause undesired operation of the device.

This equipment complies with IC RSS-102 radiation exposure limits set forth for an uncontrolled environment.

L'émetteur/récepteur exempt de licence contenu dans le présent appareil est conforme aux CNR d'Innovation, Sciences et Développement économique Canada applicables aux appareils radio exempts de licence. L'exploitation est autorisée aux deux conditions suivantes :

- (1) L'appareil ne doit pas produire de brouillage;
- (2) L'appareil doit accepter tout brouillage radioélectrique subi, même si le brouillage est susceptible d'en compromettre le fonctionnement.

Cet équipement est conforme aux limites d'exposition aux radiations IC CNR-102 établies pour un environnement non contrôlé.

RF Exposure Compliance

This equipment complies with FCC/IC RSS-102 radiation exposure limits set forth for an uncontrolled environment. This equipment should be installed and operated with minimum distance 20cm between the radiator and your body. This transmitter must not be co-located or operating in conjunction with any other antenna or transmitter.

Cet équipement est conforme aux limites d'exposition aux radiations IC CNR-102 établies pour un environnement non contrôlé. Cet équipement doit être installé et utilisé avec une distance minimale de 20cm entre le radiateur et votre corps. Cet émetteur ne doit pas être colocalisé ou fonctionner en conjonction avec une autre antenne ou un autre émetteur.



AlgoLaser Website



AlgoLaser Community



AlgoLaser Support

Follow us! #AlgoLaser

 AlgoLaser Official

 AlgoLaser_Official

 Algolaserofficial

 algo.laser

 AlgoLaser Official User Group

 AlgoLaser Official



MADE IN CHINA



www.algolaser.com/support/

此页不印刷

蓝色色号: PANTONE 2955 C

橙色色号: PANTONE 16-1358TP (Orange Tiger)

版本 / REV.		修订内容 / Revision Note			日期 / Date	确认人 / Check By	
比例 SCALE	1:1	单位 UNIT	毫米 mm	深圳奥菲诺科技有限公司			
版本 REV.	A-01						
核准 APR.		图号 Drawing NO.	Pixi-A-01	材料 Material	封面 200g铜版纸 内页 80g铜版纸	数量 QTY.	1
审核 CHK.		品名 P/N.	Pixi说明书	装订方式 ST.	骑马钉	页次 Page.	68
绘图 DRAWN.	曾玲玲	机型 Model.	Algo Pixi	物料编码: Part NO.		日期 Date.	2025.04.1